

A decorative horizontal band with a blue background and a white line-art pattern of interlocking gears. The gears are of various sizes and orientations, creating a complex mechanical texture.

**Operator's Manual**

**1000 and 2000**

**Product Families**

**International**

**Models**

**OM4118EN**

# Operator's Manual

2005 MAY  
Rev. 1 2005 SEPTEMBER  
OM4118EN

## Allison Transmission

### INTERNATIONAL MODELS

1000 and 2000 Product Families  
Includes Allison 4<sup>th</sup> Generation Controls

1000	2100	2200	2500
1000 MH	2100 MH	2200 MH	2500 MH
1000 SP	2100 SP	2200 SP	2500 SP



Allison Transmission, General Motors Corporation  
P.O. Box 894 Indianapolis, Indiana 46206-0894  
[www.allisontransmission.com](http://www.allisontransmission.com)

# NOTES

# TABLE OF CONTENTS

## INTRODUCTION

KEEPING THAT ALLISON ADVANTAGE . . . . .	7
A BRIEF DESCRIPTION OF THE ALLISON 1000 AND 2000 PRODUCT FAMILY TRANSMISSIONS . . . . .	11
ELECTRONIC CONTROL SYSTEM . . . . .	11
TORQUE CONVERTER . . . . .	12
PLANETARY GEARS AND CLUTCHES . . . . .	13
COOLER CIRCUIT . . . . .	13

## SHIFT SELECTORS

DESCRIPTION OF AVAILABLE TYPES . . . . .	14
OPERATION OF THE SHIFT SELECTOR . . . . .	14
RANGE SELECTION—ALL 1000 AND 2200 TRANSMISSION MODELS WITH PARK PAWL AND P (PARK) POSITION . . . . .	17
RANGE SELECTION—ALL 2100 AND 2500 TRANSMISSION MODELS WITH PB (AUTO-APPLY PARKING BRAKE) POSITION . . . . .	21
RANGE SELECTION—ALL 1000 AND 2000 PRODUCT FAMILY TRANSMISSIONS WITHOUT EITHER P (PARK) OR PB (AUTO-APPLY PARKING BRAKE) POSITIONS . . . . .	25

## DRIVING TIPS

PREVENT MAJOR PROBLEMS . . . . .	29
TURNING THE VEHICLE ON/OFF . . . . .	29
MAXIMUM VEHICLE LOADING . . . . .	30
ACCELERATOR CONTROL . . . . .	31
PRIMARY/SECONDARY SHIFT SCHEDULES . . . . .	31
KICKDOWN . . . . .	31
OUTPUT SPEED INDICATOR . . . . .	32
DIAGNOSTIC CODES . . . . .	32
RANGE INHIBIT(ED) LIGHT . . . . .	32
CHECK TRANS OR MALFUNCTION INDICATOR LIGHT . . . . .	32
SHIFT INHIBITS . . . . .	33
USING THE ENGINE TO SLOW THE VEHICLE . . . . .	35
RANGE PRESELECTION . . . . .	36
REVERSE . . . . .	37
REFUSE PACKER STEP SWITCH . . . . .	37
TWO-SPEED AXLE (Some General Transmission Applications) . . . . .	37
DRIVING ON SNOW OR ICE . . . . .	37
ROCKING OUT . . . . .	38
OPERATING TEMPERATURES . . . . .	38
HIGH FLUID TEMPERATURE . . . . .	39

PARKING BRAKE . . . . .	39
PARK PAWL . . . . .	40
PARKING/LEAVING VEHICLE WITH ENGINE RUNNING . . . . .	41
TOWING OR PUSHING . . . . .	42
SURGING NATURAL GAS ENGINES . . . . .	43

**POWER TAKEOFF**

POWER TAKEOFF (PTO) SYSTEMS . . . . .	44
TURBINE-DRIVEN POWER TAKEOFF (PTO) . . . . .	44
SPLIT-SHAFT POWER TAKEOFF (PTO) . . . . .	48

**CARE AND MAINTENANCE**

PERIODIC INSPECTIONS AND CARE . . . . .	49
IMPORTANCE OF PROPER TRANSMISSION FLUID LEVEL . . . . .	50
TRANSMISSION FLUID CHECK . . . . .	50
KEEPING FLUID CLEAN . . . . .	54
FLUID RECOMMENDATIONS . . . . .	54
TRANSMISSION FLUID AND FILTER CHANGE INTERVALS . . . . .	56
TRANSMISSION FLUID CONTAMINATION . . . . .	58
TRANSMISSION FLUID AND FILTER CHANGE PROCEDURE . . . . .	59
BREATHER . . . . .	61

**DIAGNOSTICS**

DIAGNOSTIC CODES AND TOOLS . . . . .	62
--------------------------------------	----

**CUSTOMER SERVICE**

OWNER ASSISTANCE . . . . .	63
SERVICE LITERATURE . . . . .	65
ALLISON TRANSMISSION REGIONAL OFFICES . . . . .	66

## **TRADEMARK USAGE**

The following trademarks are the property of the companies indicated:

- DEXRON<sup>®</sup> is a registered trademark of the General Motors Corporation.
- TranSynd<sup>™</sup> is a trademark of Castrol Ltd.
- Allison DOC<sup>™</sup> is a trademark of General Motors Corporation.

## WARNINGS, CAUTIONS, NOTES

**IT IS YOUR RESPONSIBILITY** to be completely familiar with the warnings and cautions described in this manual. It is, however, important to understand that these warnings and cautions are not exhaustive. Allison Transmission could not possibly know, evaluate, and advise the service trade of all conceivable ways in which service might be done or of the possible hazardous consequences of each way. The vehicle manufacturer is responsible for providing information related to the operation of vehicle systems (including appropriate warnings, cautions, and notes). Consequently, Allison Transmission has not undertaken any such broad evaluation. Accordingly, **ANYONE WHO USES A SERVICE PROCEDURE OR TOOL WHICH IS NOT RECOMMENDED BY ALLISON TRANSMISSION OR THE VEHICLE MANUFACTURER MUST** first be thoroughly satisfied that neither personal safety nor equipment safety will be jeopardized by the service methods selected.

Proper service and repair is important to the safe, reliable operation of the equipment. The service procedures recommended by Allison Transmission (or the vehicle manufacturer) and described in this manual are effective methods for performing service operations. Some of these service operations require the use of tools specially designed for the purpose. The special tools should be used when and as recommended.

Three types of headings are used in this manual to attract your attention. These warnings and cautions advise of specific methods or actions that can result in personal injury, damage to the equipment, or cause the equipment to become unsafe.



**WARNING:** A warning is used when an operating procedure, practice, etc., if not correctly followed, could result in personal injury or loss of life.



**CAUTION:** A caution is used when an operating procedure, practice, etc., if not strictly observed, could result in damage to or destruction of equipment.



**NOTE:** A note is used when an operating procedure, practice, etc., is essential to highlight.

---

# INTRODUCTION

---

## KEEPING THAT ALLISON ADVANTAGE



V01724

Allison **1000 and 2000 Product Family** transmissions provide many advantages for the driver who must “stop and go” or change speeds frequently. Driving is easier, safer, and more efficient.

The 1000 and 2000 Product Family transmissions are rugged and designed to provide long, trouble-free service. This manual will help you gain maximum benefits from your **ALLISON**-equipped vehicle.



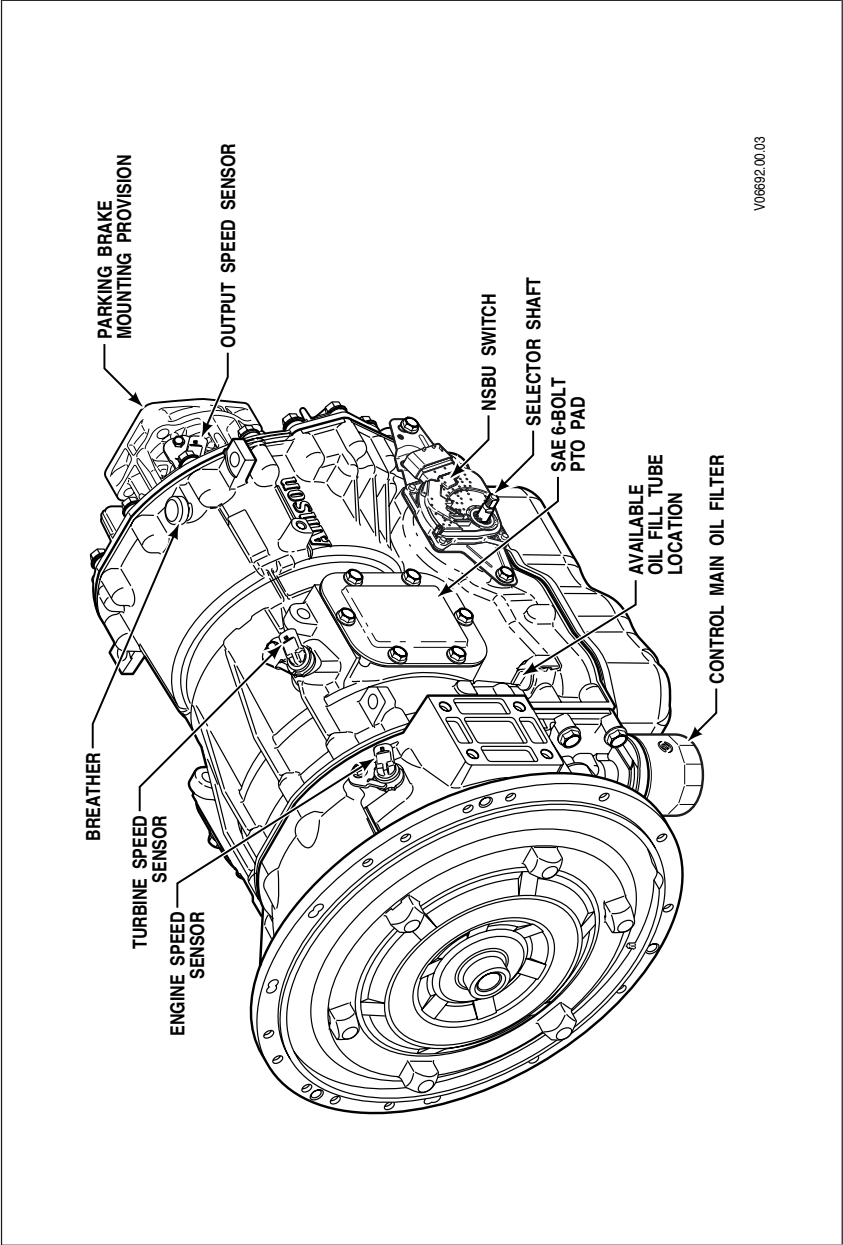

V06692.00.03

Figure 1. 1000 and 2000 Product Family—Left-Front View (Prior to Allison 4<sup>th</sup> Generation Controls)

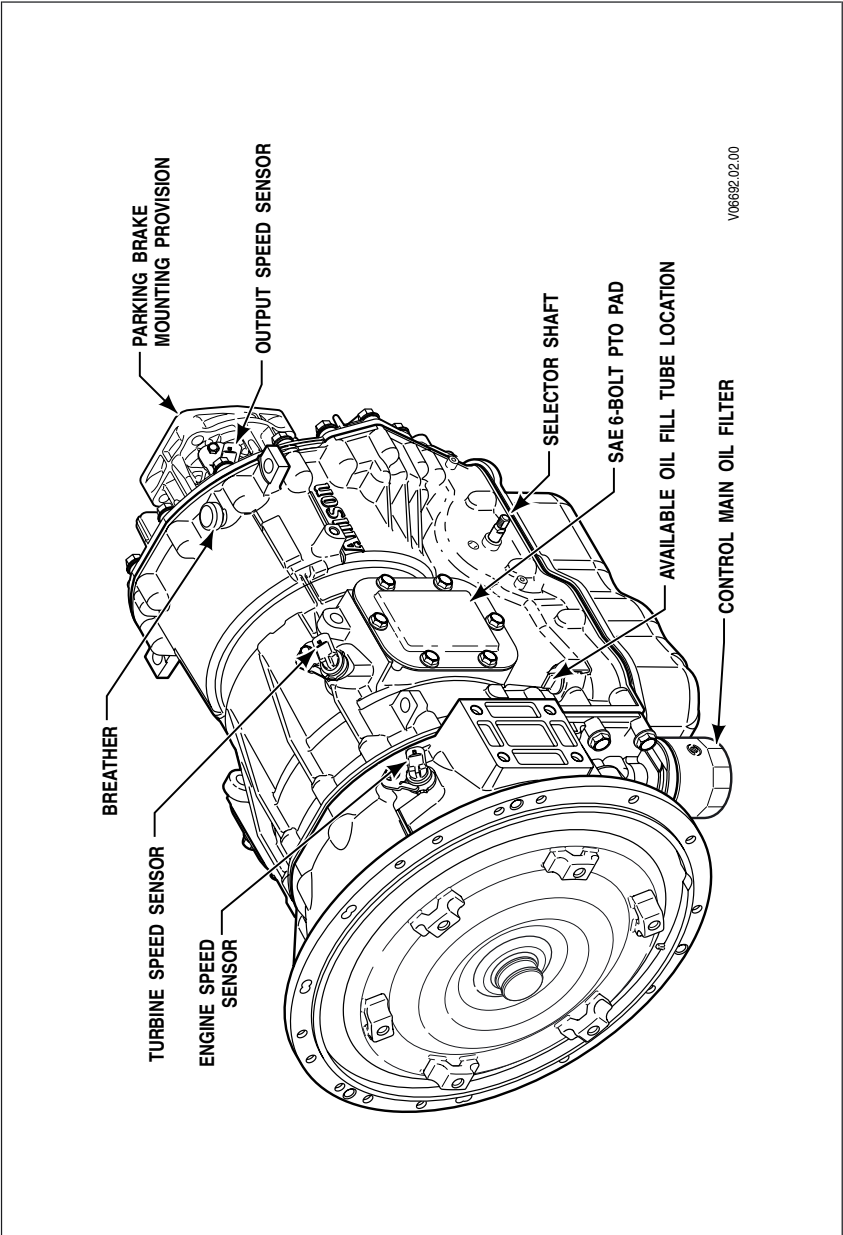

V06682.02.00

Figure 2. 1000 and 2000 Product Family—Left-Front View (Allison 4<sup>th</sup> Generation Controls)

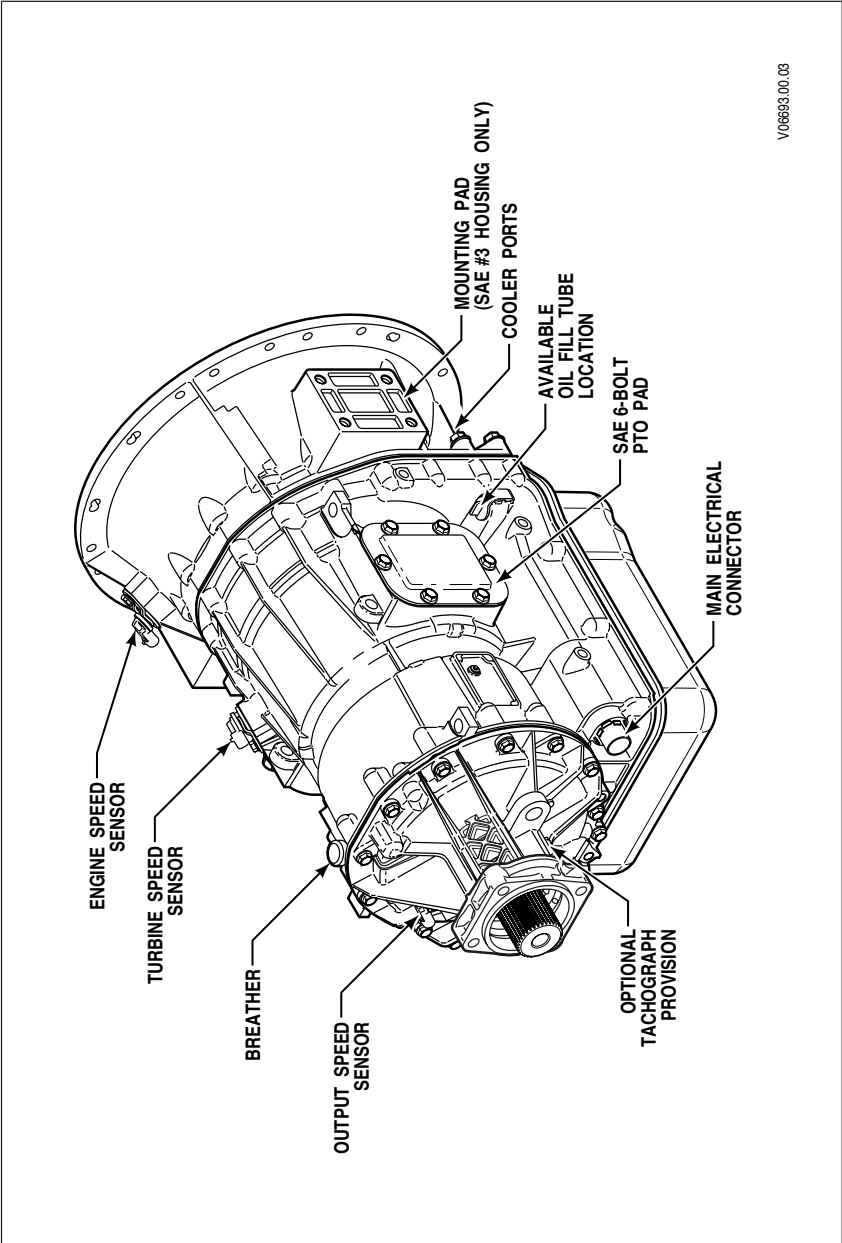

V06693.00.03

Figure 3. 1000 and 2000 Product Family—Right-Rear View

## A BRIEF DESCRIPTION OF THE ALLISON 1000 AND 2000 PRODUCT FAMILY TRANSMISSIONS

The 1000 and 2000 Product Family transmissions are fully automatic, torque-converter driven, electronically controlled transmissions best suited for light-medium duty, on-highway applications.

- **1000 and 2200 Models**—These transmission models are best suited for light duty on-highway, truck, and bus applications.
- **2100 and 2500 Models**—These transmission models are best suited for single-axle medium duty on-highway, truck, and bus applications, including rear-engine vehicle configurations.

All transmissions have up to five forward ranges and one reverse. All clutches are hydraulically-actuated, spring-released, and have automatic compensation for wear. Gearing is helical type, arranged in planetary sets. Electronic controls provide automatic gear selection in each drive range and automatic engagement of the torque converter (lockup) clutch.

Each transmission series contains features which have been designed for specific vocational needs. Refer to your nearest Allison distributor or dealer for information about feature availability for a specific transmission vocation.

1000 and 2000 Product Family transmissions may include a provision to mount a Power Takeoff (PTO), a PTO drive gear, and a park pawl. The park pawl exists but cannot be engaged in some vehicle configurations (e.g., some rear engine vehicles with air brakes). For these configurations, the **P** (Park) position is not used.

## ELECTRONIC CONTROL SYSTEM

The 1000 and 2000 Product Family control system consists of five major components connected by customer-furnished wiring harnesses. The five major components are:

- Transmission Control Module (TCM)
- Engine throttle position sensor (TPS) or direct electronic communication of throttle information
- Engine, turbine, and output speed sensors
- Internal Mode Switch (IMS)
- Control valve body

The control valve body contains solenoids and a pressure switch manifold to position and monitor control valve operation. The pressure switch manifold also contains a thermistor to monitor sump fluid temperature. The throttle position sensor (or engine-to-transmission communication link), speed sensors, pressure switch manifold, and IMS communicate information to the TCM. The TCM processes this information and then sends signals to actuate specific solenoids

located within the control valve body in the transmission. These solenoids control both oncoming and off-going clutch pressures to provide closed-loop shift control by matching input rpm during a shift to a previously established desired profile that is programmed into the TCM.

The 1000 and 2000 Product Family electronic control system has an “adaptive shifting” feature. Adaptive shifting helps optimize shift quality by monitoring critical characteristics of clutch engagement and making on-going adjustments to improve subsequent shifts. The transmission shift calibration is based on several different types of shifts, e.g., full throttle, part throttle, closed throttle—upshifts, downshifts, etc. Each shift is associated with specific speed and throttle position parameters. In order to optimize each type of shift for normal driving, shift controls must experience operation and shifting in a wide variety of operating conditions.

A “drive in” period under varied driving conditions is required before the adaptive controls can be expected to optimize each and every shift. In general, shift quality will begin to converge to their “adapted” level following several shifts of a particular shift type.

## **TORQUE CONVERTER**

The torque converter consists of the following four elements:

- Pump—input element driven directly by the engine
- Turbine—output element hydraulically driven by the pump
- Stator—reaction (torque multiplying) element
- Lockup Clutch—mechanically couples the pump and turbine when engaged; controlled by TCM

When the pump turns faster than the turbine, the torque converter is multiplying torque. When the turbine approaches the speed of the pump, the stator starts to rotate with the pump and turbine. When this occurs, torque multiplication stops and the torque converter functions as a fluid coupling.

The lockup clutch is located inside the torque converter and consists of the following elements:

- Piston and backplate—driven by the engine
- Clutch plate/damper (located between the piston and the backplate)—splined to the converter turbine

The lockup clutch/torsional damper is engaged and released in response to electronic signals from the TCM. Lockup clutch engagement provides a direct drive from the engine to the transmission gearing. This eliminates converter slippage and maximizes fuel economy and vehicle speed. The lockup clutch releases at lower speeds or when the TCM detects conditions requiring it to be released.

The torsional damper absorbs engine torsional vibration to prevent transmitting vibrations through the powertrain.

## **PLANETARY GEARS AND CLUTCHES**

A series of three helical planetary gear sets and shafts provides the mechanical gear ratios and direction of travel for the vehicle. The planetary gear sets are controlled by five multiplate clutches that work in pairs to produce up to five forward speeds and one reverse speed. The clutches are applied and released hydraulically in response to electronic signals from the TCM to the appropriate solenoids.

## **COOLER CIRCUIT**

The transmission fluid is cooled by a remote-mounted oil cooler. The bottom of the transmission torque converter housing provides for the direct mounting of a control main filter and includes two ports to facilitate the attachment of the oil cooler lines.

---

# SHIFT SELECTORS

---

## DESCRIPTION OF AVAILABLE TYPES

The 1000 and 2000 Product Family transmissions use lever-type shift selectors. The shift positions on the shift selector can vary according to the OEM-supplied shift selector installed.

## OPERATION OF THE SHIFT SELECTOR

The shift selector is used by the operator to select the following ranges:

- **P** (Park) for transmissions with park pawls
- **PB** (Auto-Apply Parking Brake) for vehicles with automatically engaged parking brakes
- **R** (Reverse)
- **N** (Neutral)
- **D** (Drive)\*
- **4** (Fourth Range)\*\*
- **3** (Third Range)\*\*
- **2** (Second Range)\*\*
- **1** (First Range)

Ranges are selected by moving the lever to the desired selector position (**P**, **PB**, **R**, **N**, **D**, **4**, **3**, **2**, or **1**). Five speed transmission models have five forward ranges, first through fifth. Four speed models have four forward ranges, first through fourth. When a forward range has been selected, the transmission automatically upshifts through each range. As the vehicle slows, the transmission will downshift automatically through each range.

\* The shift selector position representing this gear range may be labeled “5” (for the highest gear in the range), “OD” (for Overdrive), “D” (for the normal Drive position), or “1–5” (for the complete gear range).

\*\* In calibrations with five forward ranges, one of these selector positions will not be available.

The following tables list the shift selector positions and corresponding ranges for all 1000 and 2000 Product Family transmissions.

**All 1000 And 2200 Transmission Models  
With P (Park) Position**

<b>Shift Selector Position</b>	<b>Range</b>	<b>Shift Selector Position</b>	<b>Range</b>	<b>Shift Selector Position</b>	<b>Range</b>
<b>P (Park)</b>	Neutral*	<b>P (Park)</b>	Neutral*	<b>P (Park)</b>	Neutral*
<b>R (Reverse)</b>	Reverse	<b>R (Reverse)</b>	Reverse	<b>R (Reverse)</b>	Reverse
<b>N (Neutral)</b>	Neutral	<b>N (Neutral)</b>	Neutral	<b>N (Neutral)</b>	Neutral
<b>D (Drive)**</b>	1-5	<b>D (Drive)**</b>	1-5	<b>D (Drive)**</b>	1-5 (1-4)***
<b>4 (Fourth)</b>	1-4	<b>4 (Fourth)</b>	1-4	<b>3 (Third)</b>	1-3
<b>3 (Third)</b>	1-3	<b>2 (Second)</b>	1-2	<b>2 (Second)</b>	1-2
<b>1 (First)</b>	1	<b>1 (First)</b>	1	<b>1 (First)</b>	1
* With Park Pawl engaged					
** The shift selector position representing this gear range may be labeled "5" (for the highest gear in the range), "OD" (for Overdrive), "D" (for the normal Drive position), or "1-5" (for the complete gear range)					
*** 1-4 in Trailing Mode or 4-Speed Calibration					

**All 2100 And 2500 Transmission Models  
With PB (Auto-Apply Parking Brake) Position**

<b>Shift Selector Position</b>	<b>Range</b>	<b>Shift Selector Position</b>	<b>Range</b>	<b>Shift Selector Position</b>	<b>Range</b>
<b>PB (Auto-Apply Parking Brake)</b>	Neutral*	<b>PB (Auto-Apply Parking Brake)</b>	Neutral*	<b>PB (Auto-Apply Parking Brake)</b>	Neutral*
<b>R (Reverse)</b>	Reverse	<b>R (Reverse)</b>	Reverse	<b>R (Reverse)</b>	Reverse
<b>N (Neutral)</b>	Neutral	<b>N (Neutral)</b>	Neutral	<b>N (Neutral)</b>	Neutral
<b>D (Drive)**</b>	1-5	<b>D (Drive)**</b>	1-5	<b>D (Drive)**</b>	1-5 (1-4)***
<b>4 (Fourth)</b>	1-4	<b>4 (Fourth)</b>	1-4	<b>3 (Third)</b>	1-3
<b>3 (Third)</b>	1-3	<b>2 (Second)</b>	1-2	<b>2 (Second)</b>	1-2
<b>1 (First)</b>	1	<b>1 (First)</b>	1	<b>1 (First)</b>	1
* With Auto-Apply Parking Brake engaged					
** The shift selector position representing this gear range may be labeled "5" (for the highest gear in the range), "OD" (for Overdrive), "D" (for the normal Drive position), or "1-5" (for the complete gear range).					
*** 1-4 in Trailing Mode or 4-Speed Calibration					





**All 1000 and 2000 Product Family Transmissions  
Without Either P (Park) or PB (Auto-Apply Parking Brake) Positions**

<b>Shift Selector Position</b>	<b>Range</b>	<b>Shift Selector Position</b>	<b>Range</b>	<b>Shift Selector Position</b>	<b>Range</b>
<b>R (Reverse)</b>	Reverse	<b>R (Reverse)</b>	Reverse	<b>R (Reverse)</b>	Reverse
<b>N (Neutral)</b>	Neutral	<b>N (Neutral)</b>	Neutral	<b>N (Neutral)</b>	Neutral
<b>D (Drive)**</b>	1-5	<b>D (Drive)**</b>	1-5	<b>D (Drive)**</b>	1-5 (1-4)***
<b>4 (Fourth)</b>	1-4	<b>4 (Fourth)</b>	1-4	<b>3 (Third)</b>	1-3
<b>3 (Third)</b>	1-3	<b>2 (Second)</b>	1-2	<b>2 (Second)</b>	1-2
<b>1 (First)</b>	1	<b>1 (First)</b>	1	<b>1 (First)</b>	1
** The shift selector position representing this gear range may be labeled "5" (for the highest gear in the range), "OD" (for Overdrive), "D" (for the normal Drive position), or "1-5" (for the complete gear range) *** 1-4 in Trailing Mode or 4-Speed Calibration					

There are several features of the 1000 and 2000 Product Family transmissions that can inhibit transmission shifting. See the SHIFT INHIBITS section of this manual.

With an Allison-equipped vehicle, selecting the right moment to upshift or downshift during changing road and traffic conditions is not necessary. The Allison 1000 and 2000 Product Family transmission does it for you. However, knowledge of the ranges and when to select them will make vehicle control and your job even easier.

# RANGE SELECTION—ALL 1000 AND 2200 TRANSMISSION MODELS WITH PARK PAWL AND P (PARK) POSITION

<p><b>ALL 1000 AND 2200 TRANSMISSION MODELS WITH P (PARK) POSITION</b></p>	
	<p><b>WARNING:</b> For vehicles containing 1000 and 2200 transmission models with <b>P</b> (Park) selector position, follow this procedure each time the operator’s station will be unoccupied with the engine running:</p> <ol style="list-style-type: none"> <li>1. Bring the vehicle to a complete stop using the service brake.</li> <li>2. Make sure the engine is at low idle rpm.</li> <li>3. Put the transmission in <b>P</b> (Park).</li> <li>4. Engage the park pawl by slowly releasing the service brake.</li> <li>5. If a parking brake is present, apply the parking brake. Make sure the parking brake is properly engaged.</li> <li>6. Apply the emergency brakes and make sure they are properly engaged.</li> <li>7. Chock the wheels and take any other steps necessary to keep the vehicle from moving.</li> </ol> <p>If this procedure is not followed, the vehicle can move unexpectedly and cause injury and/or property damage.</p>
<p><b>P</b></p>	<p>Use <b>P</b> (Park) for the following:</p> <ul style="list-style-type: none"> <li>• To turn on or turn off the engine</li> <li>• To check vehicle accessories</li> <li>• To operate the engine at idle for longer than five minutes</li> <li>• For stationary operation of the power takeoff (if your vehicle is equipped with a PTO)</li> </ul> <p>This position places the transmission in <b>N</b> (Neutral) and engages the park pawl.</p>
	<p><b>WARNING:</b> <b>R</b> (Reverse) may not be obtained due to an active inhibitor. Check for the illumination of the <b>RANGE INHIBIT(ED)</b> light or <b>CHECK TRANS (CHECK ENGINE)</b> light. See the SHIFT INHIBITS section of this manual.</p>

**ALL 1000 AND 2200 TRANSMISSION MODELS WITH P (PARK) POSITION**



**WARNING:** To help avoid injury and/or property damage caused by unexpected vehicle movement, do not make shifts from **R** (Reverse) to **N** (Neutral) without applying the service brakes, parking brake, or emergency brake. Selecting **N** (Neutral) does not apply vehicle brakes unless an auxiliary system to apply a parking brake is installed.



**CAUTION:** Do not idle in **R** (Reverse) for more than five minutes. Extended idling in **R** (Reverse) can cause transmission overheating and damage. Always select **P** (Park) whenever time at idle exceeds five minutes.

**R**

**R** (Reverse) is used to back the vehicle. Completely stop the vehicle and let the engine return to idle before shifting from a forward range to **R** (Reverse) or from **R** (Reverse) to a forward range. The reverse warning signal is activated when the shift selector is in this position.



**WARNING:** To help avoid injury or property damage caused by unexpected vehicle movement, do not make shifts to or from **N** (Neutral) without manually or automatically applying an appropriate vehicle brake.



**WARNING:** DO NOT allow the vehicle to “coast” in **N** (Neutral). There is no engine braking in **N** (Neutral). You could lose control of the vehicle, causing property damage or personal injury. Coasting in neutral can cause severe transmission damage.

**N**

This position places the transmission in **N** (Neutral). Used for starting the engine and stationary operation.

**ALL 1000 AND 2200 TRANSMISSION MODELS WITH P (PARK) POSITION**



**WARNING:** **D** (Drive) and other forward ranges may not be obtained due to an active inhibitor. The range selected may not be obtained, resulting in unexpected vehicle movement. To help avoid injury and/or property damage, always apply the service brake when selecting **D** (Drive) or other forward ranges. Check for the **RANGE INHIBIT(ED)** light or the **CHECK TRANS (CHECK ENGINE)** light.



**WARNING:** To help avoid injury and/or property damage caused by unexpected vehicle movement, do not make shifts from a forward range to **N** (Neutral) without applying the service brakes, parking brake, or emergency brake. Selecting **N** (Neutral) does not apply vehicle brakes unless an auxiliary system to apply a parking brake is installed.



**CAUTION:** Do not idle in **D** (Drive) or any forward range for more than five minutes. Extended idling in **D** (Drive) can cause transmission overheating and damage. Always select **P** (Park) whenever time at idle exceeds five minutes.



**NOTE:** Turn off the vehicle **HIGH IDLE** switch, if present, before shifting from **N** (Neutral) to **D** (Drive) or **R** (Reverse). **D** (Drive) or **R** (Reverse) will not be attained unless the shift is made with the engine at idle.

**D\***

Use **D** (Drive) for normal driving. The transmission will initially attain first range when **D** (Drive) is selected. As vehicle speed increases, the transmission will upshift automatically through each available range up to **4 (FOURTH)** or **5 (FIFTH)**. As the vehicle slows, the transmission will downshift automatically.  
 \* The shift selector position representing this gear range may be labeled “5” (for the highest gear in the range), “OD” (for Overdrive), “D” (for the normal Drive position), or “1–5” (for the complete gear range).

**ALL 1000 AND 2200 TRANSMISSION MODELS WITH P (PARK) POSITION**



**WARNING:** The transmission incorporates a hold feature to prohibit upshifting above the range selected during normal driving. For downhill operation, select a lower transmission range. If the engine governed speed is exceeded in the held range, however, the transmission will upshift to the next higher range to prevent engine damage. To avoid injury and/or property damage due to loss of vehicle control, use the vehicle brakes to prevent exceeding engine governed speed in the held range.



**WARNING:** To avoid loss of control, use a combination of downshifting, braking, and other retarding devices. Downshifting to a lower transmission range increases engine braking and can help you maintain control. The transmission has a feature to prevent automatic upshifting above the lower range selected. However, during downhill operation, if engine governed speed is exceeded in the lower range, the transmission will upshift to the next higher range to prevent engine damage. This will reduce engine braking and could cause a loss of control. Apply the vehicle brakes or other retarding device to prevent exceeding engine governed speed in the lower range selected.

**4\***  
**3\***

Use **4 (FOURTH)** or **3 (THIRD)** for city traffic and braking on steep downgrades.  
\* **3** for shift selectors with **P, R, N, D, 3, 2, 1**  
Actual ranges available depend on programming by vehicle manufacturer.

**3\***  
**2\***

Use **3 (THIRD)** or **2 (SECOND)** for heavy city traffic and braking on steeper downgrades.  
\* **3** for shift selectors with **P, R, N, D, 4, 3, 1**  
Actual ranges available depend on programming by vehicle manufacturer.



**1**

Use **1 (FIRST)** range for the following:

- When pulling through mud and deep snow
- When maneuvering in tight spaces
- While driving up or down very steep grades

First range provides the vehicle with its maximum driving torque and maximum engine braking effect.

## RANGE SELECTION—ALL 2100 AND 2500 TRANSMISSION MODELS WITH PB (AUTO-APPLY PARKING BRAKE) POSITION

ALL 2100 AND 2500 TRANSMISSION MODELS WITH PB (AUTO-APPLY PARKING BRAKE) POSITION	
	<p><b>WARNING:</b> For vehicles containing 2100 and 2500 transmission models with <b>PB</b> (Auto-Apply Parking Brake) selector position, follow this procedure each time the operator's station will be unoccupied with the engine running:</p> <ol style="list-style-type: none"> <li>1. Bring the vehicle to a complete stop using the service brake.</li> <li>2. Make sure the engine is at low idle rpm.</li> <li>3. Put the transmission in <b>PB</b> (Auto-Apply Parking Brake). Make sure the parking brake is properly engaged.</li> <li>4. Apply the emergency brake and make sure it is properly engaged.</li> <li>5. Chock the wheels and take any other steps necessary to keep the vehicle from moving.</li> </ol> <p>If this procedure is not followed, the vehicle can move unexpectedly and cause injury and/or property damage.</p>
<p><b>PB</b></p>	<p>Use <b>PB</b> (Auto-Apply Parking Brake) for the following:</p> <ul style="list-style-type: none"> <li>• To turn on or turn off the engine</li> <li>• To check vehicle accessories</li> <li>• To operate the engine at idle for longer than five minutes</li> <li>• For stationary operation of the power takeoff (if your vehicle is equipped with a PTO)</li> </ul> <p>This position places the transmission in <b>N</b> (Neutral) and engages the parking brake.</p>
	<p><b>WARNING:</b> <b>R</b> (Reverse) may not be obtained due to an active inhibitor. Check for the illumination of the <b>RANGE INHIBIT</b> light or <b>CHECK TRANS (CHECK ENGINE)</b> light. See the <b>SHIFT INHIBITS</b> section of this manual.</p>

**ALL 2100 AND 2500 TRANSMISSION MODELS WITH PB (AUTO-APPLY PARKING BRAKE) POSITION**



**WARNING:** To help avoid injury and/or property damage caused by unexpected vehicle movement, do not make shifts from **R** (Reverse) to **N** (Neutral) without applying the service brakes, parking brake, or emergency brake. Selecting **N** (Neutral) does not apply vehicle brakes unless an auxiliary system to apply a parking brake is installed.



**CAUTION:** Do not idle in **R** (Reverse) for more than five minutes. Extended idling in **R** (Reverse) can cause transmission overheating and damage. Always select **PB** (Auto-Apply Parking Brake) whenever time at idle exceeds five minutes.

**R**

**R** (Reverse) is used to back the vehicle. Completely stop the vehicle and let the engine return to idle before shifting from a forward range to **R** (Reverse) or from **R** (Reverse) to a forward range. The reverse warning signal is activated when the shift selector is in this position.



**WARNING:** To help avoid injury or property damage caused by unexpected vehicle movement, do not make shifts to or from **N** (Neutral) without manually or automatically applying an appropriate vehicle brake.



**WARNING:** DO NOT allow the vehicle to “coast” in **N** (Neutral). There is no engine braking in **N** (Neutral). You could lose control of the vehicle, causing property damage or personal injury. Coasting in neutral can cause severe transmission damage.

**N**

This position places the transmission in **N** (Neutral). Used for starting the engine and stationary operation.

**ALL 2100 AND 2500 TRANSMISSION MODELS WITH PB (AUTO-APPLY PARKING BRAKE) POSITION**



**WARNING:** **D** (Drive) and other forward ranges may not be obtained due to an active inhibitor. The range selected may not be obtained, resulting in unexpected vehicle movement. To help avoid injury and/or property damage, always apply the service brake when selecting **D** (Drive) or other forward ranges. Check for the **RANGE INHIBIT(ED)** light or the **CHECK TRANS (CHECK ENGINE)** light.



**WARNING:** To help avoid injury and/or property damage caused by unexpected vehicle movement, do not make shifts from a forward range to **N** (Neutral) without applying the service brakes, parking brake, or emergency brake. Selecting **N** (Neutral) does not apply vehicle brakes unless an auxiliary system to apply a parking brake is installed.



**CAUTION:** Do not idle in **D** (Drive) or any forward range for more than five minutes. Extended idling in **D** (Drive) can cause transmission overheating and damage. Always select **PB** (Auto-Apply Parking Brake) whenever time at idle exceeds five minutes.



**NOTE:** Turn off the vehicle **HIGH IDLE** switch, if present, before shifting from **N** (Neutral) to **D** (Drive) or **R** (Reverse). **D** (Drive) or **R** (Reverse) will not be attained unless the shift is made with the engine at idle.

**D\***

Use **D** (Drive) for normal driving. The transmission will initially attain first range when **D** (Drive) is selected. As vehicle speed increases, the transmission will upshift automatically through each available range up to **4 (FOURTH)** or **5 (FIFTH)**. As the vehicle slows, the transmission will downshift automatically.  
 \* The shift selector position representing this gear range may be labeled “5” (for the highest gear in the range), “OD” (for Overdrive), “D” (for the normal Drive position), or “1–5” (for the complete gear range).



**ALL 2100 AND 2500 TRANSMISSION MODELS WITH PB (AUTO-APPLY PARKING BRAKE) POSITION**



**WARNING:** The transmission incorporates a hold feature to prohibit upshifting above the range selected during normal driving. For downhill operation, select a lower transmission range. If the engine governed speed is exceeded in the held range, however, the transmission will upshift to the next higher range to prevent engine damage. To avoid injury and/or property damage due to loss of vehicle control, use the vehicle brakes to prevent exceeding engine governed speed in the held range.



**WARNING:** To avoid loss of control, use a combination of downshifting, braking, and other retarding devices. Downshifting to a lower transmission range increases engine braking and can help you maintain control. The transmission has a feature to prevent automatic upshifting above the lower range selected. However, during downhill operation, if engine governed speed is exceeded in the lower range, the transmission will upshift to the next higher range to prevent engine damage. This will reduce engine braking and could cause a loss of control. Apply the vehicle brakes or other retarding device to prevent exceeding engine governed speed in the lower range selected.

**4\***  
**3\***

Use **4 (FOURTH)** or **3 (THIRD)** for city traffic and braking on steep downgrades.  
\* **3** for shift selectors with **PB, R, N, D, 3, 2, 1**  
Actual ranges available depend on programming by vehicle manufacturer.

**3\***  
**2\***

Use **3 (THIRD)** or **2 (SECOND)** for heavy city traffic and braking on steeper downgrades.  
\* **3** for shift selectors with **PB, R, N, D, 4, 3, 1**  
Actual ranges available depend on programming by vehicle manufacturer.





**1**

Use **1 (FIRST)** range for the following:



- When pulling through mud and deep snow
- When maneuvering in tight spaces
- While driving up or down very steep grades

First range provides the vehicle with its maximum driving torque and maximum engine braking effect.

## RANGE SELECTION—ALL 1000 AND 2000 PRODUCT FAMILY TRANSMISSIONS WITHOUT EITHER P (PARK) OR PB (AUTO-APPLY PARKING BRAKE) POSITIONS

ALL 1000 AND 2000 PRODUCT FAMILY TRANSMISSIONS WITHOUT EITHER P (PARK) OR PB (AUTO-APPLY PARKING BRAKE) POSITIONS	
	<p><b>WARNING:</b> For vehicles containing 1000 and 2000 Product Family transmissions without either <b>P</b> (Park) or <b>PB</b> (Auto-Apply Parking Brake) selector positions, each time you park the vehicle or leave the operator's station with the engine running, do the following:</p> <ol style="list-style-type: none"> <li>1. Bring the vehicle to a complete stop using the service brake.</li> <li>2. Make sure the engine is at low idle rpm.</li> <li>3. Put the transmission in <b>N</b> (Neutral).</li> <li>4. Apply the emergency brake and/or parking brake and make sure they are properly engaged.</li> <li>5. If the operator's station will be unoccupied with the engine running, chock the wheels and take any other steps necessary to keep the vehicle from moving.</li> </ol> <p>If the procedure is not followed, the vehicle may move suddenly and cause injury and/or property damage.</p>
	<p><b>WARNING:</b> <b>R</b> (Reverse) may not be obtained due to an active inhibitor. Check for the illumination of the <b>RANGE INHIBIT</b> light or <b>CHECK TRANS (CHECK ENGINE)</b> light. See the <b>SHIFT INHIBITS</b> section of this manual.</p>
	<p><b>WARNING:</b> To help avoid injury and/or property damage caused by unexpected vehicle movement, do not make shifts from <b>R</b> (Reverse) to <b>N</b> (Neutral) without applying the service brakes, parking brake, or emergency brake. Selecting <b>N</b> (Neutral) does not apply vehicle brakes unless an auxiliary system to apply a parking brake is installed.</p>
	<p><b>CAUTION:</b> Do not idle in <b>R</b> (Reverse) for more than five minutes. Extended idling in <b>R</b> (Reverse) can cause transmission overheating and damage. Always select <b>N</b> (Neutral) whenever time at idle exceeds five minutes.</p>

**ALL 1000 AND 2000 PRODUCT FAMILY TRANSMISSIONS WITHOUT EITHER P (PARK) OR PB (AUTO-APPLY PARKING BRAKE) POSITIONS**

<p><b>R</b></p>	<p><b>R</b> (Reverse) is used to back the vehicle. Completely stop the vehicle and let the engine return to idle before shifting from a forward range to <b>R</b> (Reverse) or from <b>R</b> (Reverse) to a forward range. The reverse warning signal is activated when the shift selector is in this position.</p>
	<p><b>WARNING:</b> To help avoid injury or property damage caused by unexpected vehicle movement, do not make shifts to or from <b>N</b> (Neutral) without manually or automatically applying an appropriate vehicle brake.</p>
	<p><b>WARNING:</b> DO NOT allow the vehicle to “coast” in <b>N</b> (Neutral). There is no engine braking in <b>N</b> (Neutral). You could lose control of the vehicle, causing property damage or personal injury. Coasting in neutral can cause severe transmission damage.</p>
<p><b>N</b></p>	<p>Use <b>N</b> (Neutral) for the following:</p> <ul style="list-style-type: none"> <li>• To turn on or turn off the engine</li> <li>• To check vehicle accessories</li> <li>• To operate the engine at idle for longer than five minutes</li> <li>• For stationary operation of the power takeoff (if your vehicle is equipped with a PTO)</li> </ul>
	<p><b>WARNING:</b> <b>D</b> (Drive) and other forward ranges may not be obtained due to an active inhibitor. The range selected may not be obtained, resulting in unexpected vehicle movement. To help avoid injury and/or property damage, always apply the service brake when selecting <b>D</b> (Drive) or other forward ranges. Check for the <b>RANGE INHIBIT(ED)</b> light or the <b>CHECK TRANS (CHECK ENGINE)</b> light.</p>

**ALL 1000 AND 2000 PRODUCT FAMILY TRANSMISSIONS WITHOUT EITHER P (PARK) OR PB (AUTO-APPLY PARKING BRAKE) POSITIONS**



**WARNING:** To help avoid injury and/or property damage caused by unexpected vehicle movement, do not make shifts from a forward range to **N** (Neutral) without applying the service brakes, parking brake, or emergency brake. Selecting **N** (Neutral) does not apply vehicle brakes unless an auxiliary system to apply a parking brake is installed.



**CAUTION:** Do not idle in **D** (Drive) or any forward range for more than five minutes. Extended idling in **D** (Drive) can cause transmission overheating and damage. Always select **N** (Neutral) whenever time at idle exceeds five minutes.



**NOTE:** Turn off the vehicle **HIGH IDLE** switch, if present, before shifting from **N** (Neutral) to **D** (Drive) or **R** (Reverse). **D** (Drive) or **R** (Reverse) will not be attained unless the shift is made with the engine at idle.

**D\***

Use **D** (Drive) for normal driving. The transmission will initially attain first range when **D** (Drive) is selected. As vehicle speed increases, the transmission will upshift automatically through each available range up to **4 (FOURTH)** or **5 (FIFTH)**. As the vehicle slows, the transmission will downshift automatically.

\* The shift selector position representing this gear range may be labeled “5” (for the highest gear in the range), “OD” (for Overdrive), “D” (for the normal Drive position), or “1–5” (for the complete gear range).



**WARNING:** The transmission incorporates a hold feature to prohibit upshifting above the range selected during normal driving. For downhill operation, select a lower transmission range. If the engine governed speed is exceeded in the held range, however, the transmission will upshift to the next higher range to prevent engine damage. To avoid injury and/or property damage due to loss of vehicle control, use the vehicle brakes to prevent exceeding engine governed speed in the held range.

**ALL 1000 AND 2000 PRODUCT FAMILY TRANSMISSIONS WITHOUT EITHER P (PARK) OR PB (AUTO-APPLY PARKING BRAKE) POSITIONS**



**WARNING:** To avoid loss of control, use a combination of downshifting, braking, and other retarding devices. Downshifting to a lower transmission range increases engine braking and can help you maintain control. The transmission has a feature to prevent automatic upshifting above the lower range selected. However, during downhill operation, if engine governed speed is exceeded in the lower range, the transmission will upshift to the next higher range to prevent engine damage. This will reduce engine braking and could cause a loss of control. Apply the vehicle brakes or other retarding device to prevent exceeding engine governed speed in the lower range selected.

**4\***  
**3\*** Use **4 (FOURTH)** or **3 (THIRD)** for city traffic and braking on steep downgrades.  
\* **3** for shift selectors with **R, N, D, 3, 2, 1**  
Actual ranges available depend on programming by vehicle manufacturer.

**3\***  
**2\*** Use **3 (THIRD)** or **2 (SECOND)** for heavy city traffic and braking on steeper downgrades.  
\* **3** for shift selectors with **R, N, D, 4, 3, 1**  
Actual ranges available depend on programming by vehicle manufacturer.

**1** Use **1 (FIRST)** range for the following:

- When pulling through mud and deep snow.
- When maneuvering in tight spaces.
- While driving up or down very steep grades.

First range provides the vehicle with its maximum driving torque and maximum engine braking effect.

---

# DRIVING TIPS

---

## PREVENT MAJOR PROBLEMS

Minor problems can be kept from becoming major problems if you notify your service management or an Allison Transmission distributor or dealer when any of these conditions occur:

- Shifting feels abnormal.
- Transmission leaks fluid.
- Unusual transmission-related sounds (changes in sound caused by normal engine thermostatic fan cycling, while climbing a long grade with a heavy load, have been mistaken for transmission-related sounds).
- **CHECK TRANS** light or **RANGE INHIBIT(ED)** light comes on frequently.

## TURNING THE VEHICLE ON/OFF

Before turning on or off the engine, the driver must verify that the service brake is engaged and one of the following ranges has been selected and engaged:

- **P** (Park)
- **PB** (Auto-Apply Parking Brake)
- **N** (Neutral) if **P** (Park) or **PB** (Auto-Apply Parking Brake) is not available



**NOTE:** The vehicle should not start unless these ranges have been selected. If the vehicle starts in any other range, seek service immediately.

---

Transmission operation at cold ambient temperatures may require preheating or the use of a lower viscosity transmission fluid. See the **FLUID RECOMMENDATIONS** section in this manual.

Even when the engine is warm and capable of full-throttle output, the transmission should not be taken out of **P** (Park), **PB** (Auto-Apply Parking Brake), or **N** (Neutral) for at least thirty seconds to allow for buildup of transmission fluid pressure.

## MAXIMUM VEHICLE LOADING



**WARNING:** Operation with excessive loads can cause transmission damage and unexpected vehicle movement. To help avoid injury, property damage and/or transmission damage, do not exceed the GVW and GCW values listed in the Maximum Vehicle Loading table, or the OEM vehicle rating, whichever is less.

### Maximum Vehicle Loading

Model	Application	GVW		GCW	
		kg	lbs	kg	lbs
1000	General	9000	19,850	11 800	26,000
	Refuse	7500	16,540	N/A	N/A
	Transit Bus, Shuttle Bus, Coach, and Non-North American School Bus (T/C/NNASB)	7500	16,540	N/A	N/A
1000 MH	Motorhome	10 000	22,000	11 800	26,000
1000 SP	Specialty	10 000	22,000	11 800	26,000
2100	General	12 000	26,500	12 000	26,500
	Refuse	11 000	24,200	N/A	N/A
	T/C/NNASB	12 000	26,500	N/A	N/A
2100 MH	Motorhome	12 000	26,500	13 600	30,000
2100 SP	Specialty	12 000	26,500	13 600	30,000
2200	General	11 800	26,000	11 800	26,000
	T/C/NNASB	11 800	26,000	11 800	26,000
2200 MH	Motorhome	11 800	26,000	11 800	26,000
2200 SP	Specialty	11 800	26,000	11 800	26,000
2500	General	15 000	33,000	15 000	33,000
	Refuse	11 000	24,200	N/A	N/A
	Non-North American School Bus	15 000	33,000	15 000	33,000
2500 MH	Motorhome	15 000	33,000	15 000	33,000
2500 SP	Specialty	15 000	33,000	15 000	33,000

## ACCELERATOR CONTROL



**WARNING:** To avoid injury or property damage caused by sudden movement of the vehicle, do not make shifts from **N** (Neutral) to a forward range or **R** (Reverse) when the throttle is open. The vehicle will lurch forward or rearward and the transmission can be damaged. Avoid this condition by making shifts from **N** (Neutral) to a forward range or **R** (Reverse) only when the throttle is closed and service brakes are applied.

The position of the accelerator pedal influences when automatic shifting occurs. When the pedal is fully depressed, upshifts will occur automatically at high engine speeds. A partially depressed position of the pedal will cause the upshifts to occur at lower engine speeds. An electronic throttle position signal tells the TCM how much the operator has depressed the pedal. Excessive throttle position may inhibit the directional shift.

## PRIMARY/SECONDARY SHIFT SCHEDULES

The points at which shifts occur depend upon predetermined speeds and other operating conditions. A transmission “shift calibration” includes several sets of shift points which may be used according to current or anticipated operating conditions. Some shift schedules may be inhibited as a result of operating conditions, such as engine or transmission fluid temperature. Shift schedules may be changed through selection of a remote (usually dash-mounted) switch—which is typically associated with a change in anticipated vehicle operation.

The TCM includes the capacity for two separate and distinct shift calibrations (customer-selectable), one for use in primary mode of operation and one in secondary mode.

- **Primary**—This shift schedule is typically used for all normal vehicle operations.
- **Secondary**—This is an alternate shift schedule that the TCM uses upon request. Not all vehicles will be equipped with a secondary shift schedule. The request can be interlocked with a vehicle component, or be operator-controlled using a dash-mounted switch.

Your vehicle may have a dash-mounted light that illuminates when the secondary mode is active.

## KICKDOWN

Some vehicles have a “kickdown” feature that allows the operator to choose between an “Economy” primary shift schedule and “Performance” secondary shift schedule. The throttle pedal will have a detent feel when full-throttle is achieved



using “Economy” shift points. When the operator “steps through” this detent, the function is activated and “Performance” shift points are achieved.

## **OUTPUT SPEED INDICATOR**

Your vehicle may contain a light or other indicator that is activated when a preset output speed has been exceeded in the vehicle, transmission, or auxiliary equipment. The output speed may occur in either the forward or reverse direction. This indicator may be used to alert the operator that a specific overspeed condition has occurred or to indicate that a minimum or maximum operating speed was attained.

## **DIAGNOSTIC CODES**

See detailed information in the DIAGNOSTICS section.

## **RANGE INHIBIT(ED) LIGHT**

The red or amber **RANGE INHIBIT(ED)** warning light is located on or near the shift selector. The purpose of this indicator is to alert the operator that transmission operation is being inhibited and that range shifts being requested by the operator may not occur. When certain operating conditions are detected by the TCM, the controls will command the transmission to be locked in the range currently in use. If the torque converter clutch is applied when the condition is detected, the clutch will be disengaged concurrently with the activation of the **RANGE INHIBIT(ED)** light.

Each time the engine is started, the **RANGE INHIBIT(ED)** light will illuminate, then turn off after two seconds. If the light does not illuminate during ignition, or if the light remains on after ignition, the transmission system should be checked immediately.

For the conditions under which shift inhibits occur, see the SHIFT INHIBITS section in this manual.

## **CHECK TRANS OR MALFUNCTION INDICATOR LIGHT**

The red or amber **CHECK TRANS** light or Malfunction Indicator Light (**MIL**) is located on the dash panel. A **MIL** is present on vehicles that meet industry On Board Diagnostics II (OBD II) requirements. A **CHECK TRANS** light is present on vehicles not subject to industry OBD II requirements.

Each time the engine is started, the **CHECK TRANS** light or **MIL** will illuminate, then turn off after two seconds. If the light does not illuminate during ignition, or if the light remains on after ignition, the transmission system should be checked immediately.

Illumination of the **CHECK TRANS** light or **MIL** at any time after start-up indicates that a problem has been detected. The TCM will register a diagnostic code and shifts may be restricted. Depending upon the severity of the problem, operation may continue in order to reach service assistance. The TCM may not respond to shift selector requests since upshifts and downshifts may be restricted and direction changes may not occur.

Illumination of the **CHECK TRANS** light or **MIL** at any time after start-up may indicate a problem with the engine or transmission Refer to the **DIAGNOSTICS** section for more information on diagnostic codes.

## SHIFT INHIBITS

The transmission control system will inhibit shifting to protect the transmission from some types of abusive operation, in response to diagnostic trouble codes, and to satisfy transmission feature/option requirements. These shift inhibits fall within the following types:

- Above-idle neutral-to-range shifts
- Forward/reverse directional shifts
- Transmission problems
- Auxiliary equipment operation

### Above-Idle Neutral-to-Range Shifts.



**WARNING:** To avoid injury or property damage caused by sudden movement of the vehicle, do not make shifts from **N** (Neutral) to a forward range or **R** (Reverse) when the throttle is open. The vehicle will lurch forward or rearward and the transmission can be damaged. Avoid this condition by making shifts from **N** (Neutral) to a forward range or **R** (Reverse) only when the throttle is closed and service brakes are applied.

Above-idle (greater than 900 rpm) shifts from **N** (Neutral) to **R** (Reverse) or **N** (Neutral) to a forward range are normally inhibited (except in emergency vehicles or some other type of specialized equipment).

When these shifts are inhibited, the **RANGE INHIBIT(ED)** light will illuminate. See the **RANGE INHIBIT(ED) LIGHT** section in this manual for further information.

## Forward/Reverse Directional Shifts.



**WARNING:** To avoid injury or property damage caused by sudden movement of the vehicle, do not make shifts from **N** (Neutral) to a forward range or **R** (Reverse) when the throttle is open. The vehicle will lurch forward or rearward and the transmission can be damaged. Avoid this condition by making shifts from **N** (Neutral) to a forward range or **R** (Reverse) only when the throttle is closed and service brakes are applied.

Forward/reverse directional changes are typically not permitted if appreciable output shaft speed is detected.

When these shifts are inhibited, the **RANGE INHIBIT(ED)** light will illuminate. See the **RANGE INHIBIT(ED) LIGHT** section in this manual for further information.

**Transmission Problems.** Lights such as the **RANGE INHIBIT(ED)**, **CHECK TRANS**, or Malfunction Indicator Light (**MIL**), and a flashing **PRNDL** display will be illuminated when the transmission detects a functional concern.

An illuminated **RANGE INHIBIT(ED)** light or a flashing **PRNDL** display indicates that the Transmission Control Module (TCM) has detected a condition where directional shifts are not allowed to be made. This inhibited state can be a self-clearing or lasting condition depending on the amount of time the condition is present.

The following conditions may cause an inhibited state:

- Engine speed too high
- Throttle percentage incorrect
- Output speed movement

See the **RANGE INHIBIT(ED) LIGHT** or **CHECK TRANS OR MALFUNCTION INDICATOR LIGHT** section in this manual for further information.

Depending on the severity of the Diagnostic Trouble Code (DTC), the transmission may default to an operating state predefined by the TCM such as “Limp Home”. “Limp Home” will temporarily limit normal transmission operation until the vehicle can be driven to a service location and the severity of the problem is determined. The transmission will remain in the “Limp Home” state until the problem has been corrected. Following an engine restart, the transmission may obtain **THIRD**, **NEUTRAL**, or **REVERSE**. Reference the Sales and Service Directory (SA2229EN) for the current listing of Allison Transmission authorized distributor and service dealers.

See the **RANGE INHIBIT(ED) LIGHT** and **SHIFT INHIBITS** sections in this manual for further information.

**Auxiliary Equipment Operation.** The TCM will prevent shifts from **P** (Park), **PB** (Auto-Apply Parking Brake), or **N** (Neutral)-to-range when auxiliary equipment is in operation (e.g., a wheelchair lift). For some vehicles such as buses, shifts from **P** (Park), **PB** (Auto-Apply Parking Brake), or **N** (Neutral)-to-range will be prevented unless the brake pedal is depressed.

## USING THE ENGINE TO SLOW THE VEHICLE



**WARNING:** The transmission incorporates a hold feature to prohibit upshifting above the range selected during normal driving. For downhill operation, select a lower transmission range. If the engine governed speed is exceeded in the held range, however, the transmission will upshift to the next higher range to prevent engine damage. To avoid injury and/or property damage due to loss of vehicle control, use the vehicle brakes to prevent exceeding engine governed speed in the held range.



**WARNING:** To avoid loss of control, use a combination of downshifting, braking, and other retarding devices. Downshifting to a lower transmission range increases engine braking and can help you maintain control. The transmission has a feature to prevent automatic upshifting above the lower range selected. However, during downhill operation, if engine governed speed is exceeded in the lower range, the transmission will upshift to the next higher range to prevent engine damage. This will reduce engine braking and could cause a loss of control. Apply the vehicle brakes or other retarding device to prevent exceeding engine governed speed in the lower range selected.

To use the engine as a braking force, select the next lower range. If the vehicle is exceeding the maximum speed for this range, use the service brakes and/or other retarding devices to slow the vehicle. When a lower speed is reached, the TCM will automatically downshift the transmission. Engine braking provides good speed control for going down grades. When the vehicle is heavily loaded, or the grade is steep, it may be desirable to preselect a lower range before reaching the grade. If the engine-governed speed is exceeded, the transmission will upshift automatically to the next range.



**CAUTION:** Using the engine brake on wet or slippery roads may cause loss of traction on the drive wheels—your vehicle may slide out of control. To help avoid injury or property damage, turn the engine brake enable to OFF when driving on wet or slippery roads.

## RANGE PRESELECTION

Range preselection means selecting a lower range to match driving conditions you encounter or expect to encounter. Learning to take advantage of preselected shifts will give you better control on slick or icy roads and on downgrades.

Downshifting to a lower range increases engine braking. The selection of a lower range often prevents cycling between that range and the next higher range on a series of short up-and-down hills.



**NOTE:** Preselecting during normal operation may result in reduced fuel economy.

---

Manual range downshifts will not occur until a calibration value of output speed is reached. When a range downshift is manually selected and the transmission output speed is above the calibration value, the transmission will stay in the range it was in even though a lower range was requested. Apply the vehicle service brakes or some retarding device to reduce the transmission output speed to the calibration value and then the shift to the lower range will occur.

Two shift schedules are used with range preselection: hold upshift and preselect downshift.

**Hold Upshift.** This shift schedule keeps the transmission from shifting above the selected range. This shift schedule permits upshifts to occur if an engine overspeed condition could result by the transmission remaining (by operator selection) in a range lower than its highest range. When the hold feature is activated, transmission upshift points occur at engine speeds which are higher than normal upshifts in order to “hold” the transmission from upshifting beyond the current range.



**WARNING:** The transmission incorporates a hold feature to prohibit upshifting above the range selected during normal driving. For downhill operation, select a lower transmission range. If the engine governed speed is exceeded in the held range, however, the transmission will upshift to the next higher range to prevent engine damage. To avoid injury and/or property damage due to loss of vehicle control, use the vehicle brakes to prevent exceeding engine governed speed in the held range.

**Preselect Downshift.** This shift schedule is used when the driver preselects a lower range. The operator may preselect any range below **D** (Drive) on the shift selector at any time. When a range has been “preselected” in this manner, shift points to and from ranges above the preselected range are higher than the normal shift points. The transmission will downshift when an engine overspeed condition will not result after the shift. Shifts below the preselected range are not affected.

## REVERSE

Putting the transmission into **R** (Reverse) may activate vehicle backup lights and/or reverse warning devices.

To achieve **REVERSE** range in some European transit and tour buses, an instrument panel-mounted switch must be pressed simultaneously with the **R** (Reverse) shift selector button.

## REFUSE PACKER STEP SWITCH

When personnel are on the rear step of a refuse packer, the transmission will operate in **FIRST** and **NEUTRAL** only.

- An operator request to upshift beyond **FIRST** or to shift to **REVERSE** is ignored by the TCM.
- If the transmission is in **REVERSE**, the TCM will cause the transmission to shift to **NEUTRAL**.
- If the transmission is in a forward range higher than **FIRST**, the TCM will invoke “preselect downshifts” until **FIRST** is attained.

## TWO-SPEED AXLE (Some General Transmission Applications)

The two-speed axle may be shifted while the vehicle is moving. However, the axle or vehicle manufacturer’s recommendations should be followed for shifting the axle. It is recommended that axle shifts be made with the transmission in the highest range, or vehicle stopped, to prevent a transmission shift from coinciding with an axle shift.

## DRIVING ON SNOW OR ICE

If possible, reduce your speed and select a lower range before you lose traction. Select the range that will not exceed the speed you expect to maintain. Accelerate or decelerate very gradually to prevent losing traction. It is very important to reduce speed gradually when a lower range is selected. It is important that you reach the selected lower range before attempting to accelerate. This will avoid an unexpected downshift during acceleration.



**NOTE:** If the Anti-lock Brake System (ABS) is activated, the lockup clutch is automatically disengaged.

---

## ROCKING OUT



**WARNING:** To avoid injury or property damage caused by sudden movement of the vehicle, do not make shifts from **N** (Neutral) to a forward range or **R** (Reverse) when the throttle is open. The vehicle will lurch forward or rearward and the transmission can be damaged. Avoid this condition by making shifts from **N** (Neutral) to a forward range or **R** (Reverse) only when the throttle is closed and service brakes are applied.



**CAUTION:** If the wheels are stuck and not turning, do not apply full power for more than 10 seconds in either **D** (Drive) or **R** (Reverse). Full power for more than 10 seconds under these conditions will cause the transmission to overheat. If the transmission overheats, shift to **N** (Neutral) and operate the engine at 1200–1500 rpm until it cools (2–3 minutes).

If the vehicle is stuck in deep sand, snow, or mud, it may be possible to rock it out. Shift to **D** (Drive) and apply steady, light throttle (never full throttle). When the vehicle has rocked forward as far as it will go, apply and hold the vehicle service brakes. Allow the engine to return to idle; then select **R** (Reverse). Release the brakes and apply a steady, light throttle and allow the vehicle to rock in **R** (Reverse) as far as it will go. Again, apply and hold the service brakes and allow the engine to return to idle. This procedure may be repeated in **D** (Drive) and **R** (Reverse) if each directional shift continues to move the vehicle a greater distance. Never make **N** (Neutral)-to-**D** (Drive) or directional shift changes when the engine rpm is above idle.

## OPERATING TEMPERATURES

To properly operate the transmission, adhere to the following minimum and maximum transmission operating temperatures:

Sump, minimum continuous	40°C (100°F)
Sump, maximum intermittent	121°C (250°F)
To cooler, maximum intermittent	149°C (300°F)

Your transmission may have a converter-out transmission temperature gauge near the “to-cooler” port on the transmission converter housing.

## HIGH FLUID TEMPERATURE



**CAUTION:** Always select **P** (Park), **PB** (Auto-Apply Parking Brake), or **N** (Neutral) whenever time at idle exceeds five minutes. Extended idling in any other ranges can cause transmission overheating and damage.



**CAUTION:** Sustained use of the parking brake with the engine running and the transmission in range can cause an overheating failure of the transmission. The vehicle can contain a buzzer or dash-mounted light to alert the operator when the ignition switch is “ON”, the parking brake is applied, and the transmission selector is in range.



**CAUTION:** The engine should never be operated for more than 10 seconds at full throttle with the transmission in range and the output stalled. Prolonged operation of this type will cause the transmission fluid temperature to become excessively high and will cause severe overheat damage to the transmission.

Your vehicle may have a dash indicator or other alarm that turns on when the transmission sump temperature or to-cooler temperature exceeds specified limits.

If the transmission overheats during normal operations, do the following:

- Check the fluid level in the transmission. See the CARE AND MAINTENANCE section of this manual.
- Safely stop the vehicle and check the cooling system. If it appears to be functioning properly, run the engine at 1200–1500 rpm with the transmission in **N** (Neutral). This should reduce the transmission and engine temperatures to normal operating levels in 2 or 3 minutes. If temperatures do not decrease, reduce the engine rpm.
- If high temperature in either the engine or transmission persists, stop the engine and have the overheating condition investigated by service management.

## PARKING BRAKE

For shift selectors with a **PB** (Auto-Apply Parking Brake) position, selecting **PB** (Auto-Apply Parking Brake) places the transmission in **NEUTRAL** and automatically engages the parking brake. For shift selectors without a **PB** (Auto-Apply Parking Brake) position, the parking brake must be manually engaged. Your vehicle may have an indicator light that illuminates when the parking brake is applied.





**CAUTION:** Do not apply the transmission-mounted parking brake with the vehicle in motion. Transmission and/or driveline damage can result. In the event of a dynamic brake apply, recheck the torque of all brake mounting bolts to verify the integrity of the mount.



**CAUTION:** Sustained use of the parking brake with the engine running and the transmission in range can cause an overheating failure of the transmission. The vehicle can contain a buzzer or dash-mounted light to alert the operator when the ignition switch is “ON”, the parking brake is applied, and the transmission selector is in range.

## PARK PAWL

A park pawl is standard on 1000 and 2200 transmission models and is not available on 2100 and 2500 transmission models. The park pawl effectively grounds the transmission output shaft, thereby preventing rotation of the driveline. Provided the vehicle is stationary, selecting **P** (Park) on the shift selector places the transmission in **NEUTRAL** and engages the park pawl. The park pawl exists but cannot be engaged in some vehicle configurations using 1000 and 2200 transmission models (e.g., some rear engine vehicles with air brakes). For these configurations, the **P** (Park) position is not used.



**WARNING:** To help avoid injury and/or property damage caused by unexpected vehicle movement, do not attempt to engage **P** (Park) with the vehicle in motion (2 km/hr (1 mph) or higher). If you attempt to engage **P** (Park) with the vehicle in motion (2 km/hr (1 mph) or higher), the park pawl will ratchet, will not engage, and will not hold the vehicle. Repeated park pawl ratcheting can cause transmission damage.



**WARNING:** If the vehicle has four-wheel-drive and the transfer case is in Neutral, the vehicle can be free to roll even if the **P** (Park) position is selected. To avoid injury and/or property damage caused by unexpected movement of the vehicle, be certain that the transfer case is in “high” drive range, not Neutral, whenever the vehicle is parked.



**WARNING:** If the vehicle is equipped with a two-speed axle or two-speed transfer case which is engaged in “low”, even very low vehicle speeds can produce appreciable transmission output shaft speed. Even the slightest vehicle motion can deter engagement of the park pawl in such cases. To help avoid injury and/or property damage caused by unexpected vehicle movement, be certain that the axle or transfer case is in “high” drive range whenever the vehicle is parked and the park pawl is engaged.

**Torque Lock.** If the vehicle is parked on an incline and **P** (Park) is properly engaged, the weight of the vehicle may generate an excessive amount of torque on the park pawl in the transmission. In this situation, it may be difficult to shift the transmission out of the **P** (Park) position. This condition is commonly called “torque lock.”

To alleviate torque lock, do the following:

1. Taking the vehicle’s weight into consideration, push the vehicle uphill a small amount to release the pressure on the park pawl and permit a shift out of **P** (Park).
2. Shift the transmission out of **P** (Park) while applying the service brakes.
3. Release the parking brake.

## **PARKING/LEAVING VEHICLE WITH ENGINE RUNNING**



**WARNING:** For vehicles containing 1000 and 2200 transmission models, with **P** (Park) selector position, follow this procedure each time the operator’s station will be unoccupied with the engine running:

1. Bring the vehicle to a complete stop using the service brake.
2. Make sure the engine is at low idle rpm.
3. Put the transmission in **P** (Park).
4. Engage the park pawl by slowly releasing the service brake.
5. If a parking brake is present, apply the parking brake. Make sure the parking brake is properly engaged.
6. Apply the emergency brakes and make sure they are properly engaged.
7. Chock the wheels and take any other steps necessary to keep the vehicle from moving.

If this procedure is not followed, the vehicle can move unexpectedly and cause injury and/or property damage.



**WARNING:** For vehicles containing 2100 and 2500 transmission models with **PB** (Auto-Apply Parking Brake) selector position, follow this procedure each time the operator's station will be unoccupied with the engine running:

1. Bring the vehicle to a complete stop using the service brake.
2. Make sure the engine is at low idle rpm.
3. Put the transmission in **PB** (Auto-Apply Parking Brake). Make sure the parking brake is properly engaged.
4. Apply the emergency brakes and make sure they are properly engaged.
5. Chock the wheels and take any other steps necessary to keep the vehicle from moving.

If this procedure is not followed, the vehicle can move unexpectedly and cause injury and/or property damage.



**WARNING:** For vehicles containing 1000, 2100, 2200, and 2500 transmission models without either **P** (Park) or **PB** (Auto-Apply Parking Brake) selector positions, each time you park the vehicle or leave the operator's station with the engine running, do the following:

1. Bring the vehicle to a complete stop using the service brake.
2. Make sure the engine is at low idle rpm.
3. Put the transmission in **N** (Neutral).
4. Apply the emergency brakes and/or parking brake and make sure they are properly engaged.
5. If the operator's station will be unoccupied with the engine running, chock the wheels and take any other steps necessary to keep the vehicle from moving.

If this procedure is not followed, the vehicle can move unexpectedly and cause injury and/or property damage.

## TOWING OR PUSHING



**CAUTION:** Failure to lift the driving wheels off the road, disconnect the driveline, or remove the axle shafts before pushing or towing can cause serious transmission damage.

The engine cannot be started by pushing or towing. Before pushing or towing a vehicle, lift the drive wheels off the road, disconnect the driveline, or remove the axle shafts from the drive wheels. When the axle shafts are removed, be sure to cover the wheel openings to prevent loss of lubricant and entry of dust and dirt. An auxiliary air supply will usually be required to release the vehicle brake system.

## SURGING NATURAL GAS ENGINES

---



**NOTE:** Engine surging or engine speed cycling may occur on natural gas powered equipment. This condition typically occurs when the transmission is being operated in a hold position with throttle applied and the engine speed above full load engine governed speed. Surging may also occur at closed and part throttle. This condition is an engine characteristic and NOT a transmission concern.

---

---

# POWER TAKEOFF

---

## POWER TAKEOFF (PTO) SYSTEMS

Three types of PTO systems may be used with 1000 and 2000 Product Family transmissions:

- **Transmission-Mounted Turbine-Driven PTO**—A transmission-mounted turbine-driven PTO drive provides both an infinitely-variable PTO drive ratio and a protective hydraulic cushion against abrupt loading/unloading (during “converter mode” operation) and engine-driven PTO speed control (during “torque converter clutch mode” operation).
- **Split-Shaft PTO**—A split-shaft PTO, a chassis-mounted component, is typically used in applications which require full engine power being available to either propel the vehicle or to power auxiliary equipment through the PTO drive—but not both simultaneously. In both cases, the transmission output shaft delivers power to the split-shaft transfer case. The split-shaft transfer case is then shifted to deliver this power to either the driveline or PTO drive.
- **Flywheel-Driven PTO**—A flywheel-driven PTO, often called a “sandwich PTO,” mounts between the engine and transmission. The PTO is normally driven directly by the engine.

## TURBINE-DRIVEN POWER TAKEOFF (PTO)

The following pertains to Transmission-Mounted Turbine-Driven PTOs only.

**PTO Configuration.** The PTO is mounted on the left and/or right side of the transmission housing. The PTO drivetrain consists of a large drive gear in the transmission, an idler gear arrangement, and a smaller driven gear in the PTO. The drive gear is integral to the transmission rotating clutch housing, which rotates at the same speed as the torque converter turbine. With this drive configuration, the PTO rotates in the same direction as the engine.

Two types of transmission-mounted PTOs may be used with these transmission models.

- **Constant-drive PTO**—Used in applications which require full-time PTO operation. The PTO driven gear is in constant mesh with the drive gear and cannot be disengaged.
- **Clutch shift PTO**—Used in applications which require only part-time operation of the PTO or the capability to engage or disengage the driven equipment. Clutch shift PTO engagement/disengagement is accomplished by a hydraulic clutch mechanism in the PTO assembly. The PTO can be engaged or disengaged at any time (except when the PTO is controlled by the TCM).

### **PTO Engagement—PTO With Internal Slide Engagement.**



**CAUTION:** Only use “constant-mesh” PTOs. DO NOT use “manual shift” PTOs which engage/disengage with the PTO drive gear in the transmission or the transmission may be damaged. Only use PTOs where the sliding gear is within the PTO.

Engage the PTO drivetrain as follows:

1. With the vehicle stopped, put the shift selector in a forward range while keeping the service brakes applied.
2. Set the engine speed at idle.
3. Engage the PTO. If gears do not engage, release the brakes momentarily to allow slight vehicle movement. Engage the PTO. Repeat as needed until the PTO is engaged.
4. Shift to **N** (Neutral) and operate the PTO as needed.

Disengage the PTO drivetrain as follows:

1. Idle the engine.
2. Set the brake.
3. Place the shift selector in a drive range.
4. Stop the PTO-driven equipment.
5. Disengage the PTO.
6. Operate the vehicle in the normal matter.

**PTO Engagement—Manual Shift PTO.** Manually shifted (Cable, Electrical, Air shifted) PTOs that engage internally inside the PTO can be used.



**WARNING:** If you leave the vehicle and the engine is running, the vehicle can move unexpectedly and you or others could be injured. DO NOT leave the vehicle with the engine running unless you have taken all of the following precautions:

- Shift the transmission to **N** (Neutral), **P** (Park), or **PB** (Auto-Apply Parking Brake).
- Make sure that the engine is at low idle (500–800 rpm)
- Apply the park brake or emergency brake and make sure it is properly engaged
- Chock the wheels and take any other steps necessary to keep the vehicle from moving

On automatic transmissions, the gears in the transmission turn when the transmission is in neutral, therefore, gears clashing will occur if the PTO is shifted **into range** or **out of range** at this time.

With Turbine-Driven Gear:

1. Engine idle. With the operator seated in the driver's seat and while activating the vehicle's brake, shift transmission lever into any of the drive positions. (This will stop transmission gear from turning.)
2. Shift PTO into or out of range.
3. If the PTO does not engage, release the PTO to the disengage position. Shift the transmission to **N** (Neutral) and repeat the above steps from step 1.
4. Shift the transmission into **P** (Park) or **N** (Neutral). (This will start transmission gears turning.) If you hear a grinding or ratcheting sound turn PTO off and repeat these procedures from step 1.

**PTO Engagement—Clutch Driven.** The PTO will engage only when the PTO switch is on, the throttle position is low, and engine speed and output speed are within user-specified limits. If the PTO is controlled by the TCM, your vehicle may have a light on the dash that illuminates when the PTO is engaged.



**CAUTION:** Some vehicles “creep” in range at low vehicle speeds while maintaining a specified engine speed for PTO operation (e.g., paint strippers and feedlot trucks). DO NOT use the vehicle brakes to control vehicle speed during PTO operation. Use ONLY throttle to control both engine and vehicle speed when the transmission is in reverse or a forward range. Applying BOTH brakes and throttle will cause the transmission to overheat. Extended operation at elevated temperatures will damage the transmission.



**CAUTION:** Do not exceed the engagement and operational speed limits imposed on the driven equipment during the operation of the PTO. Exceeding the speed limits produces high hydraulic pressure in the PTO that can damage the PTO components. Consult the vehicle manufacturer's literature for these speed limits.

**PTO Operation.** The transmission operates in either converter mode or torque converter clutch mode. In converter mode, the torque converter (lockup) clutch is not engaged and the PTO is driven through the torque converter, producing a torque at the PTO drive gear that is always greater than the input torque. In torque converter clutch mode, the torque converter (lockup) clutch is engaged, the PTO drivetrain is driven at a speed proportional to the engine speed.

The PTO drive is normally in continuous converter mode operation when the transmission is in **P** (Park), **PB** (Auto-Apply Parking Brake), **R** (Reverse), **N** (Neutral), and **D** (Drive). Torque converter clutch operation in **N** (Neutral) is available for some applications. If the PTO is used with the transmission in **D** (Drive) or another forward range, transmission shifts (both converter/torque converter clutch mode shifts and shifts between gears) are based on the automatic shift sequence of the transmission shift controls. PTO drive gear speed will be affected each time a shift occurs.

With the vehicle stopped and the engine at idle, PTO output speed is dependent upon the transmission gear selection.

- If the transmission is in **D** (Drive) or **R** (Reverse), the PTO output speed is zero.
- If the transmission is in **N** (Neutral), **P** (Park), or **PB** (Auto-Apply Parking Brake), the PTO output will rotate.

In some vehicles, the transmission will shift into **N** (Neutral) regardless of the shift selector position under the following conditions:

- The PTO is enabled
- The transmission output speed is near zero
- The throttle position is near zero

To reselect a range after the PTO is turned off, the operator must shift into **N** (Neutral), then shift to the desired range.



**CAUTION:** Do not exceed the engagement and operational speed limits imposed on the driven equipment during the operation of the PTO. Exceeding the speed limits produces high hydraulic pressure in the PTO that can damage the PTO components. Consult the vehicle manufacturer's literature for these speed limits.





**CAUTION:** When PTO disengagement occurs due to an overspeed condition, the PTO will automatically re-engage at a lower, user-specified speed. Re-engaging the PTO at a high speed can cause re-engagement shock that could damage a high-inertia PTO-driven system. PTO re-engagement speed parameters must be set by qualified, Allison trained personnel.

**PTO Overspeed Protection.** All 1000 and 2000 Product Family-equipped vehicles with PTO enable have engagement and operational speed limits programmed into the TCM to help protect PTO equipment. The PTO will deactivate when operational speeds (either engine or transmission output) are exceeded. When the PTO is disengaged due to overspeed, the PTO will be automatically re-engaged at a user specified speed, which is relatively low.

## SPLIT-SHAFT POWER TAKEOFF (PTO)

For many split-shaft PTOs, holding the transmission in direct drive at all engine speeds is desirable. In this manner, the automatic range shifts are eliminated, thereby eliminating rapid torque changes which would occur at the driven equipment during a shift in the transmission. Such a condition, for instance, could create an undesirable pressure surge (and directional control problem) at the nozzle-end of a fire hose.



---

**NOTE:** Transmissions for General and Specialty applications equipped with Allison 4<sup>th</sup> Generation Controls have a control provision that supports a split-shaft PTO application. This function will allow for **THIRD** range lockup operation only. Consult your Allison distributor for additional requirements and operational information associated with this feature.

---

---

# CARE AND MAINTENANCE

---

## PERIODIC INSPECTIONS AND CARE

### Transmission Inspection.



**CAUTION:** Do not spray steam, water, or cleaning solution directly at electrical connectors or the breather. Fluids forced into electrical connectors can cause false codes and cross-talk. Steam, water, or cleaning solution forced into the breather will contaminate the transmission fluid. Seal all openings, the breather, and electrical connections before spraying steam, water, or cleaning solution on the transmission.

Clean and inspect the exterior of the transmission at regular intervals. Severity of service and operating conditions determine the frequency of these inspections. Inspect the transmission for the following:

- Loose bolts—transmission and mounting components
- Fluid leaks—repair immediately
- Loose, dirty, or improperly adjusted throttle sensor or shift selector linkage
- Damaged or loose hoses
- Worn, frayed, or improperly routed electrical harnesses
- Worn or damaged electrical connectors
- Worn or out-of-phase driveline U-joints and slip fittings
- Clogged or dirty breather

**Vehicle Inspection.** Check the vehicle cooling system occasionally for evidence of transmission fluid (which would indicate a faulty oil cooler) and for blocked or restricted air flow through the radiator or transmission cooler.

## Welding.



**CAUTION:** When welding on the vehicle:

- DO NOT WELD on the vehicle without disconnecting all control system wiring harness connectors from the TCM.
- DO NOT WELD on the vehicle without disconnecting TCM battery power and ground leads.
- DO NOT WELD on any control components.
- DO NOT CONNECT welding cables to any control components.
- PROTECT CONTROL COMPONENTS FROM SPARKS AND HEAT DURING WELDING.

A label describing on-vehicle welding precautions (ST2067EN) is available from your authorized Allison service dealer and should be installed in a conspicuous place. A vehicle used in a vocation that requires frequent modifications or repairs involving welding **must** have an on-vehicle warning label.

## IMPORTANCE OF PROPER TRANSMISSION FLUID LEVEL

Transmission fluid cools, lubricates, and transmits hydraulic power. Always maintain proper fluid level. If fluid level is too low, the torque converter and clutches do not receive an adequate supply of fluid and the transmission overheats. If the fluid level is too high, the fluid aerates—causing the transmission to shift erratically and overheat. Fluid may be expelled through the breather or dipstick tube when the fluid level is too high.

## TRANSMISSION FLUID CHECK



**WARNING:** For vehicles containing 1000 and 2200 transmission models with **P** (Park) selector position, follow this procedure each time the operator's station will be unoccupied with the engine running:

1. Bring the vehicle to a complete stop using the service brake.
2. Make sure the engine is at low idle rpm.
3. Put the transmission in **P** (Park).
4. Engage the park pawl by slowly releasing the service brake.
5. If a parking brake is present, apply the parking brake. Make sure the parking brake is properly engaged.
6. Apply the emergency brakes and make sure they are properly engaged.
7. Chock the wheels and take any other steps necessary to keep the vehicle from moving.

If this procedure is not followed, the vehicle can move unexpectedly and cause injury and/or property damage.



**WARNING:** For vehicles containing 2100 and 2500 transmission models with **PB** (Auto-Apply Parking Brake) selector position, follow this procedure each time the operator's station will be unoccupied with the engine running:

1. Bring the vehicle to a complete stop using the service brake.
2. Make sure the engine is at low idle rpm.
3. Put the transmission in **PB** (Auto-Apply Parking Brake). Make sure the parking brake is properly engaged.
4. Apply the emergency brakes and make sure they are properly engaged.
5. Chock the wheels and take any other steps necessary to keep the vehicle from moving.

If this procedure is not followed, the vehicle can move unexpectedly and cause injury and/or property damage.



**WARNING:** For vehicles containing 1000, 2100, 2200, and 2500 transmission models without either **P** (Park) or **PB** (Auto-Apply Parking Brake) selector positions, each time you park the vehicle or leave the operator's station with the engine running, do the following:

1. Bring the vehicle to a complete stop using the service brake.
2. Make sure the engine is at low idle rpm.
3. Put the transmission in **N** (Neutral).
4. Apply the emergency brakes and/or parking brake and make sure they are properly engaged.
5. If the operator's station will be unoccupied with the engine running, chock the wheels and take any other steps necessary to keep the vehicle from moving.

If this procedure is not followed, the vehicle can move unexpectedly and cause injury and/or property damage.

**Fluid Check Procedure.** Clean all dirt from around the end of the fluid fill tube before removing the dipstick. Do not allow dirt or foreign matter to enter the transmission. Dirt or foreign matter in the hydraulic system may cause undue wear of transmission parts, make valves stick, and clog passages. Check the fluid level using the following procedure and report any abnormal fluid levels to your service management or an Allison distributor or dealer.

**Cold Check Procedure.** The purpose of the cold check is to determine if the transmission has enough fluid to be operated safely until a hot check can be made.



**CAUTION:** The fluid level rises as fluid temperature rises. DO NOT fill the transmission above the “COLD CHECK” band if the transmission fluid is below normal operating temperatures. During operation, an overfull transmission can become overheated, leading to transmission damage.

Check the fluid level as follows:

1. Bring the vehicle to a complete stop on a level surface using the service brake.
2. Make sure the engine is at low idle rpm (with fast idle disabled).
3. Put the transmission in **P** (Park), **PB** (Auto-Apply Parking Brake), or **N** (Neutral).
4. Apply any other parking brake, if present, and make sure it is properly engaged.
5. Chock the wheels and take any other steps necessary to keep the vehicle from moving.
6. Run the engine at 1000–1500 rpm for at least one minute to purge air from the system. Apply the service brakes and shift to **D** (Drive), then to **N** (Neutral), and then shift to **R** (Reverse) to fill the hydraulic system. Finally, shift to **P** (Park) or **PB** (Auto-Apply Parking Brake), if available, or **N** (Neutral) and allow the engine to idle (500–800 rpm). Slowly release the service brakes.
7. With the engine running, remove the dipstick from the tube and wipe the dipstick clean.
8. Insert the dipstick into the tube and remove. Check the fluid level reading. Repeat the check procedure to verify the reading.
9. If the fluid level is within the “COLD CHECK” band (refer to Figure 4), the transmission may be operated until the fluid is hot enough to perform a “HOT RUN” check. If the fluid level is not within the “COLD CHECK” band, add or drain as necessary to bring it to the middle of the “COLD CHECK” band.

10. Perform a hot check at the first opportunity after the normal operating sump temperature of 71°C–93°C (160°F–200°F) is reached.

### Hot Check Procedure.



**CAUTION:** When performing the Hot Check procedure, the fluid must be at operating temperature to be sure of an accurate check and help prevent transmission damage. The fluid rises as temperature increases. During operation, an overfull transmission can become overheated, leading to transmission damage.



**NOTE:** If a transmission temperature gauge is not present, check fluid level when the engine water temperature gauge has stabilized and the transmission has been operated under load for at least one hour.

Operate the transmission in **D** (Drive) until the following normal operating temperatures are reached:

- **Sump temperature**—71°C–93°C (160°F–200°F)
- **Converter-out temperature**—82°C–104°C (180°F–220°F)

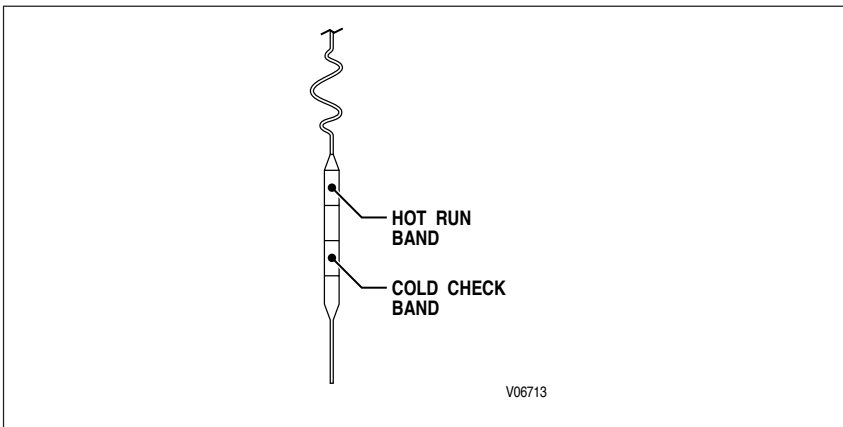

**Figure 4. Typical Dipstick Markings**

Check the fluid level as follows:

1. Bring the vehicle to a complete stop on a level surface using the service brake.
2. Make sure the engine is at low idle rpm (with fast idle disabled).

3. Put the transmission in **P** (Park), **PB** (Auto-Apply Parking Brake), or **N** (Neutral).
4. Apply any other parking brake, if present, and make sure it is properly engaged.
5. Chock the wheels and take any other steps necessary to keep the vehicle from moving.
6. With the engine running, remove the dipstick from the tube and wipe the dipstick clean.
7. Insert the dipstick into the tube and remove. Check the fluid level reading. Repeat the check procedure to verify the reading.



**NOTE:** Safe operating level is within the “HOT RUN” band on the dipstick (refer to Figure 4). The width of the “HOT RUN” band represents approximately 1.0 liter (1.06 quart) of fluid at normal operating sump temperature.

---

8. If the fluid level is not within the “HOT RUN” band, add or drain as necessary to bring the fluid level to within the “HOT RUN” band.

**Consistency of Readings.** Always check the fluid level at least twice using the procedure described above. Consistency (repeatable readings) is important to maintaining proper fluid level. If inconsistent readings persist, check the transmission breather to be sure it is clean and unclogged. If readings are still inconsistent, contact your nearest Allison distributor or dealer.

## KEEPING FLUID CLEAN

Prevent foreign material from entering the transmission by using clean containers, fillers, etc. Lay the dipstick in a clean place while filling the transmission.



**CAUTION:** Containers or fillers that have been used for antifreeze solution or engine coolant must NEVER be used for transmission fluid. Antifreeze and coolant solutions contain ethylene glycol which, if put into the transmission, can cause the clutch plates and some seals to fail.

## FLUID RECOMMENDATIONS

Hydraulic fluids (oils) used in the transmission are important influences on transmission performance, reliability, and durability. Any fluids meeting DEXRON®-III specifications are acceptable for use in the 1000 and 2000 Product Family transmissions. TranSynd™ fluids fully meet the DEXRON®-III specifications.

Make sure the fluid is qualified for use in Allison transmissions, check for a DEXRON®-III fluid license or approval numbers on the container, or consult the lubricant manufacturer. Consult your Allison Transmission dealer or distributor before using other fluid types.



**CAUTION:** Disregarding minimum fluid temperature limits can result in transmission malfunction or reduced transmission life.

When choosing the optimum viscosity grade of fluid to use, duty cycle, preheat capabilities, and/or geographical location must be taken into consideration. The table below lists the minimum fluid temperatures at which the transmission may be safely operated without preheating the fluid. Preheat with auxiliary heating equipment or by running the equipment or vehicle with the transmission in **P** (Park) or **PB** (Auto-Apply Parking Brake), if available, or **N** (Neutral) for a minimum of 20 minutes before attempting range operation.

### Transmission Fluid Operating Temperature Requirements

Viscosity Grade	Ambient Temperature Below Which Preheat is Required	
	Celsius	Fahrenheit
DEXRON®-III	-25°	-13°
TranSynd™	-30°	-22°
(Ref. SIL 13-TR-90)		

Shifting will be inhibited and torque converter clutch mode will not be reached until the transmission fluid operating temperature requirements have been met. Refer to the Transmission Fluid Operating Temperature Requirements table. As the transmission reaches normal operating temperature, all shift ranges and the torque converter clutch mode will begin to function.



## TRANSMISSION FLUID AND FILTER CHANGE INTERVALS



**CAUTION:** Transmission fluid and filter change frequency is determined by the severity of transmission service. To help avoid transmission damage, more frequent changes can be necessary than recommended in the general guidelines when operating conditions create high levels of contamination or overheating.

**Frequency.** New vehicles delivered from the OEM with a mixture of TranSynd™ and non-TranSynd™ fluid must follow fluid/filter change recommendations outlined in Schedule 1 of the Recommended Fluid and Filter Change Intervals schedules. If the customer fills the transmission with TranSynd™ or TES 295 equivalent, the change recommendations of Schedule 1 must be followed.

Upon the next oil change, if the customer reinstalls TranSynd™ or TES 295 equivalent, the fluid/filter change recommendations outlined in Schedule 2 may be used. The recommendations in Schedule 2 are based upon Allison fluid change procedures and the transmission containing 100 percent of TranSynd™ fluid.

For transmissions that contain a mixture of TranSynd™ and non-TranSynd™ fluids, refer to Schedule 1.



**NOTE:** Fluid Exchanging Machines are not recommended or recognized due to variation and inconsistencies that may not guarantee removal of 100 percent of the used fluid.

Allison Transmission requires an initial filter change for the Spin-On Control Main Filter during the first 8000 km (5000 miles) or 200 hours of service, whichever comes first. Following the initial filter change, change fluid/filters after recommended mileage, months, or hours have elapsed, whichever occurs first. Refer to the fluid change intervals listed in Schedule 1 or Schedule 2 for recommendations. The transmission sump filter is permanent and does not require replacement except at overhaul.

Severe Vocations include On/Off-Highway, Refuse, City Transit, Shuttle, and Motorhomes. General Vocations include all other vocations. Local conditions, severity of operation or duty cycle may require more or less frequent fluid change intervals that differ from the published recommended fluid change intervals of Allison Transmission. Transmission protection and fluid change intervals can be optimized by the use of fluid analysis.

The following tables are given only as a general guide for fluid and filter change intervals.

**Schedule 1. Recommended Fluid and Filter Change Intervals  
(DEXRON®-III and Mixtures of TranSynd™/TES 295 and  
Non-TranSynd™/Non-TES 295 Fluids)**

Vocation	Fluid*	Filters		
		Control Main**	Internal	Lube/Auxiliary
<b>General</b>	80 000 km (50,000 miles) 24 months 2000 hours	80 000 km (50,000 miles) 24 months 2000 hours	Overhaul	80 000 km (50,000 miles) 24 months 2000 hours
<b>Severe</b>	20 000 km (12,000 miles) 6 months 500 hours	20 000 km (12,000 miles) 6 months 500 hours	Overhaul	20 000 km (12,000 miles) 6 months 500 hours
<p>* Mixture is defined as the quantity of oil remaining in the transmission after a standard fluid change combined with the quantity of TranSynd™ that is required to fill the transmission to the proper level. A mixture of TranSynd™ or TES 295 equivalent vs. non-TranSynd™ other than as defined in this paragraph does not meet the requirements that permit the eligibility for the recommendations given in Schedule 2.</p> <p>** Control Main Spin-on Filters Only Initial 5000 miles.</p>				

**Schedule 2. Recommended Fluid and Filter Change Intervals  
(TranSynd™/TES 295 Fluid)**

Vocation	Fluid	Filters		
		Control Main**	Internal	Lube/Auxiliary
<b>General</b>	160 000 km (100,000 miles) 48 months 4000 hours	80 000 km (50,000 miles) 24 months 2000 hours	Overhaul	80 000 km (50,000 miles) 24 months 2000 hours
<b>Severe</b>	80 000 km (50,000 miles) 24 months 2000 hours	80 000 km (50,000 miles) 24 months 2000 hours	Overhaul	80 000 km (50,000 miles) 24 months 2000 hours
<p>** Control Main Spin-on Filter Only Initial 5000 miles.</p>				

**Abnormal Conditions.** Transmissions used in high cycle rate applications should use fluid analysis to be certain that a proper fluid change interval is established. Transmission fluid must be changed whenever there is evidence of dirt or a high temperature condition. A high temperature condition is indicated by the transmission fluid being discolored or having a strong odor, or by fluid analysis. Local conditions, severity of operation, or duty cycle may require more or less frequent fluid or filter change intervals.

**Fluid Analysis.** Transmission protection and fluid change intervals can be optimized by monitoring fluid oxidation according to the tests and limits shown in the following table. Fluid oxidation can be monitored through a fluid analysis firm and/or by using an oil analysis kit. Allison Transmission recommends that customers use fluid analysis as the primary method for determining fluid and filter change intervals. In the absence of a fluid analysis program the fluid change intervals listed in Schedule 1 or Schedule 2 should be followed.

- Fluid analysis firms—Consult your local telephone directory for fluid analysis firms. To make sure fluid analysis is consistent and accurate, use only one fluid analysis firm. Refer to the Technician’s Guide for Automatic Transmission Fluid, GN2055EN, for additional information.
- Oil analysis kits, part number 29537805, are available through your normal Allison Transmission parts source.

Refer to the Technician’s Guide for Automatic Transmission Fluid, GN2055EN, for additional information.

**Fluid Oxidation Measurement Limits**

Test	Limit
Viscosity	25 percent change from new fluid
Total Acid Number	+3.0* change from new fluid
* mg of KOH required to neutralize a gram of fluid.	

**TRANSMISSION FLUID CONTAMINATION**

**Fluid Examination.** At each fluid change, examine the drained fluid for evidence of dirt or water. A normal amount of condensation (not to exceed 0.2 percent maximum) will appear in the fluid during operation.

**Water.** Obvious water contamination of the transmission fluid or transmission fluid in the cooler water (in heat exchanger) indicates a leak between the water and fluid areas of the cooler. Inspect and pressure test the cooler to confirm the leak. Replace leaking coolers.



**NOTE:** Cooler water can also be contaminated by engine oil; be sure to locate the correct source of cooler water contamination.

## Engine Coolant.



**CAUTION:** If the transmission fluid is contaminated by water, not to exceed 0.2 percent maximum by volume, or any trace of ethylene glycol, disassemble the transmission and replace the following:

- Seals
- Gaskets
- Clutch/Friction plates
- Bearings
- Torque converters that cannot be disassembled
- Components that have rusted
- Solenoids that do not meet resistance specifications
- Pressure switch manifold (PSM)
- Internal Mode Switch (IMS)

Remove all traces of ethylene glycol and varnish deposits. Failure to follow this procedure decreases transmission reliability and durability.

**Metal.** Metal particles in the fluid (except for the minute particles normally trapped in the oil filter) indicate internal transmission damage. If these particles are found in the sump, the transmission must be disassembled and closely inspected to find their source. Metal contamination requires complete transmission disassembly. Clean all internal and external hydraulic circuits, cooler, and all other areas where the particles could lodge.

## TRANSMISSION FLUID AND FILTER CHANGE PROCEDURE

### Drain Fluid.

1. Drain the fluid when the transmission is at normal operating sump temperature of 71–93°C (160–200°F). Hot fluid flows quicker and drains more completely.
2. Remove the drain plug from the oil pan and allow the fluid to drain into a suitable container.
3. Examine the fluid as described in the TRANSMISSION FLUID CONTAMINATION paragraph in this Section.

### Replace Control-Main Filter.

1. Using a standard strap-type filter wrench or the J 45023 tool, remove the control-main filter (refer to Figure 5) by rotating it in the counterclockwise direction.
2. Remove the magnet from the filter attachment tube or from the top of the filter element.

3. Clean any metal debris from the magnet. Report any metal pieces larger than dust to your service management or an Allison distributor or dealer.
4. Reinstall the magnet onto the filter attachment tube.
5. Lubricate the gasket on the control-main filter with transmission fluid.
6. Install, by hand, the control-main filter until the gasket on the control-main filter touches the converter housing or cooler manifold.

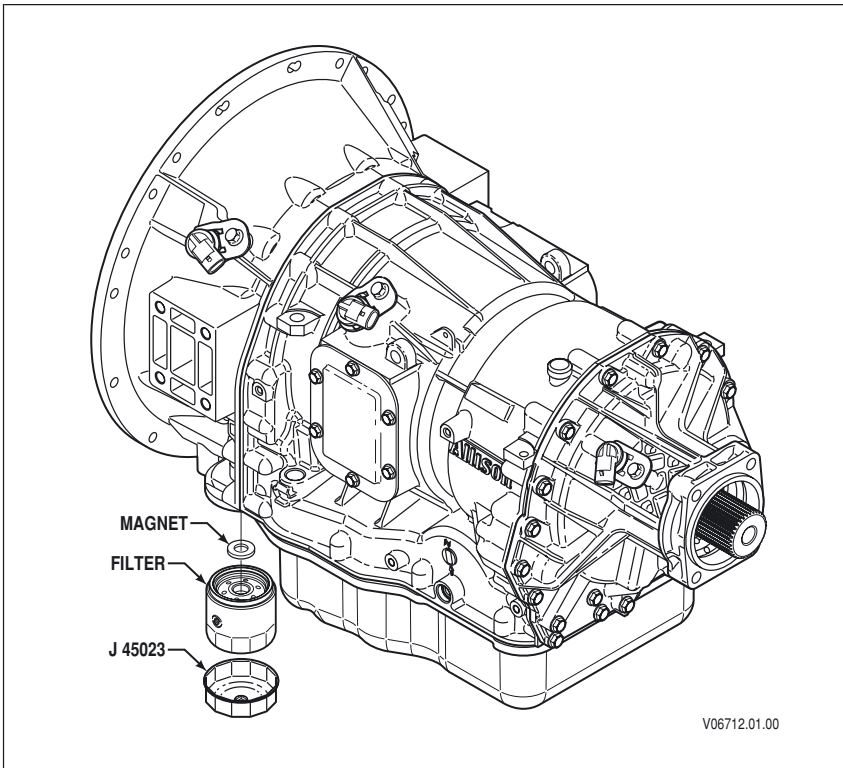

**Figure 5. Replacing the Control-Main Filter**



**CAUTION:** Turning the control-main filter more than **ONE FULL TURN** after gasket contact will damage the filter.

7. Using the J 45023 tool or by hand, turn the filter **ONE FULL TURN ONLY** after gasket contact.
8. Reinstall the drain plug and sealing washer. Tighten the drain plug to 30–40 N·m (22–30 lb ft).

**Refill Transmission.** The amount of refill fluid is less than the amount used for the initial fill. Fluid remains in the external circuits and transmission cavities after draining the transmission.

After refill, check the fluid level using the TRANSMISSION FLUID CHECK paragraph of this Manual.



**NOTE:** Quantities listed are approximations and do not include external lines and cooler hose.

### Transmission Fluid Capacity

Transmission	Sump	Initial Fill		Refill	
		Liters	Quarts	Liters	Quarts
1000 and 2000	Standard	14	14.8	10	10.6
Product Family	Shallow	12	12.7	7	7.4

## BREATHER

**Location and Purpose.** The breather is located at the top left-rear of the transmission main housing. The breather prevents air pressure buildup within the transmission and its passage must be kept clean and open.



**CAUTION:** Do not spray steam, water, or cleaning solution directly at electrical connectors or the breather. Fluids forced into electrical connectors can cause false codes and cross-talk. Steam, water, or cleaning solution forced into the breather will contaminate the transmission fluid. Seal all openings, the breather, and electrical connections before spraying steam, water, or cleaning solution on the transmission.

**Maintenance.** The amount of dust and dirt encountered will determine the frequency of breather cleaning. Use care when cleaning the transmission.

---

# DIAGNOSTICS

---

## DIAGNOSTIC CODES AND TOOLS

The illumination of the **CHECK TRANS** light or **MIL** (Malfunction Indicator Light) any time after start-up indicates that the TCM has registered a Diagnostic Trouble Code (DTC). DTCs are used to identify the nature of a malfunction.

Use any Allison DOC™ diagnostic tool to access DTCs and troubleshoot transmission complaints.

The following Allison DOC™ diagnostic tools are available:

- Allison DOC™ For PC–Service Tool—full feature service tool.
- Allison DOC™ For Fleets–Service Tool—diagnostic only.

For more information regarding Allison DOC™ diagnostic tools, please visit [www.allisontransmission.com](http://www.allisontransmission.com)—Click on “Service” and then click on “Diagnostic Tools”.

For additional help, **contact an authorized Allison Transmission distributor or service dealer or the Allison Technical Assistance Center at 800-252-5283**. Refer to the Sales and Service Directory (SA2229EN) or use the Allison Transmission Sales and Service Locator Tool on the Allison Transmission web site at [www.allisontransmission.com](http://www.allisontransmission.com) for current Allison Transmission authorized distributors and service dealers.

---

# CUSTOMER SERVICE

---

## OWNER ASSISTANCE

The satisfaction and goodwill of the owners of Allison transmissions are of primary concern to Allison Transmission, its distributors, and their dealers.

As an owner of an Allison transmission, you have service locations throughout the world that are eager to meet your parts and service needs with:

- Expert service by trained personnel.
- Emergency service 24 hours a day in many areas.
- Complete parts support.
- Sales teams to help determine your transmission requirements.
- Product information and literature.

Normally, any situation that arises in connection with the sale, operation, or service of your transmission will be handled by the distributor or dealer in your area. Check the telephone directory for the Allison Transmission service outlet nearest you or utilize Allison Transmission's Sales and Service Locator tool on the Allison Transmission web site at [www.allisontransmission.com](http://www.allisontransmission.com). You may also refer to Allison Transmission's Worldwide Sales and Service Directory (SA2229EN).

We recognize, however, that despite the best intentions of everyone concerned, misunderstandings may occur. To further assure your complete satisfaction, we have developed the following three-step procedure to be followed in the event a problem has not been handled satisfactorily.

**Step One—Discuss your problem with a member of management from the distributorship or dealership.** Frequently, complaints are the result of a breakdown in communication and can quickly be resolved by a member of management. If you have already discussed the problem with the Sales or Service Manager, contact the General Manager. All Allison Transmission dealers are associated with an Allison Transmission distributor. If the problem originates with a dealer, explain the matter to a management member of the distributorship with whom the dealer has his service agreement. The dealer will provide his Allison Transmission distributor's name, address, and telephone number on request.



**Step Two**—When it appears the problem cannot be readily resolved at the distributor level without additional assistance, **contact the Allison Technical Assistance Center at 800-252-5283**. They will place you in contact with the Regional Customer Support Manager for your area.

For prompt assistance, please have the following information available:

- Name and location of authorized distributor or dealer.
- Type and make of vehicle/equipment.
- Transmission model number, serial number, and assembly number (if equipped with electronic controls, also provide the TCM assembly number).
- Transmission delivery date and accumulated miles and/or hours of operation.
- Nature of problem.
- Chronological summary of your transmission's history.

**Step Three**—If you are still not satisfied after contacting the Regional Customer Support Manager, **present the entire matter to the Home Office by writing to the following address:**

Allison Transmission  
Manager, Warranty Administration  
PO Box 894, Mail Code 462-470-PF9  
Indianapolis, IN 46206-0894

The inclusion of all pertinent information will assist the Home Office in expediting the matter.

When contacting the Home Office, please keep in mind that ultimately the problem will likely be resolved at the distributorship or dealership using their facilities, equipment, and personnel. Therefore, it is suggested that **Step One** be followed when experiencing a problem.

Your purchase of an Allison Transmission product is greatly appreciated, and it is our sincere desire to assure complete satisfaction.

## SERVICE LITERATURE

Additional service literature is available. This service literature provides fully illustrated instructions for the operation, maintenance, service, overhaul, and parts support of your transmission. To be sure you get maximum performance and service life from your unit, you may order publications from:

SGI, Inc.

Attn: Allison Literature Fulfillment Desk

8350 Allison Avenue

Indianapolis, IN 46268

TOLL FREE: 888-666-5799

INTERNATIONAL: 317-471-4995

[www.allisontransmission.com](http://www.allisontransmission.com)

### Service Literature

Allison DOC™ For PC Users Guide	GN3433EN
Automatic Transmission Fluid Technician's Guide	GN2055EN
*In-Chassis Maintenance	JA3664EN
*In-Chassis Maintenance (Allison 4 <sup>th</sup> Generation Controls)	GN4008EN
*Mechanic's Tips	MT3190EN
*Mechanic's Tips (Allison 4 <sup>th</sup> Generation Controls)	MT4007EN
*Operator's Manual	OM4118EN
*Parts Catalog	PC3062EN
Parts Catalog CD-ROM	CD3062EN
Principles of Operation	PO3065EN
Principles of Operation (Allison 4 <sup>th</sup> Generation Controls)	PO4009EN
Service Manual	SM3191EN
Service Manual (Allison 4 <sup>th</sup> Generation Controls)	SM4006EN
Troubleshooting Manual	TS3192EN
Troubleshooting Manual (Allison 4 <sup>th</sup> Generation Controls)	TS3977EN
*Worldwide Sales and Service Directory	SA2229EN
*Also available on the internet at <a href="http://www.allisontransmission.com">www.allisontransmission.com</a>	

## **ALLISON TRANSMISSION REGIONAL OFFICES**

### **EUROPE, MIDDLE EAST, AFRICA, AND INDIA**

Allison Transmission Europe BV  
Baanhoek 188  
3361 GN Sliedrecht, The Netherlands  
31-78-6422-100

#### **ENGLAND**

Allison Transmission  
Millbrook Proving Grounds  
Midbrook, Bedford MK45 2JQ  
UK  
44-1525-408600

#### **FRANCE**

Allison Transmission  
Opel France  
1 á 9 Avenue du Marais  
B.P. 84  
95 101 Argenteuil Cedex, France  
33-1-3426-2153

#### **SPAIN**

Allison Transmission Spain  
c/o Transdiesel  
E-28820 Coslada, Madrid  
Spain  
34-91-6699-759

#### **SWEDEN**

Allison Transmission, Norden  
P.O. Box 100  
517 23 Bollebygd, Sweden  
46-33-2857-99

**AUSTRIA**  
Allison Transmission  
Almrauschweg  
A-4400 Steyr, Austria  
43-7252-46843

#### **FINLAND**

Allison Transmission  
General Motors Finland OY  
Pajuniityntie 5  
00320 Helsinki, Finland

#### **GERMANY**

Allison Transmission  
Eisenstrasse 2  
D-65428 Rüsselsheim, Germany  
49-6142-602+322

#### **ITALY**

Allison Transmission Italy  
c/o Delphi Automotive Systems  
Via Torino, 166  
10097 Collegno (TO)  
Italy  
39-011-4043.1

#### **SOUTH AFRICA**

Allison Transmission Division  
Entrance 2, Second Floor  
Sanlam Arena  
10 Cradock Avenue  
Rosebank, Johannesburg  
South Africa  
27-11-788-4682

## ASIA

### JAPAN

AISIN GM Allison Co., Ltd.  
Shinagawa East One Tower 3F  
2-16-1, Konan  
Minato-ku, Tokyo  
108-0075 Japan  
81-3-6718-1660

### BEIJING

Allison Transmission  
Beijing Representative Branch  
General Motors (China) Investment  
Company, Ltd.  
Block C Guo Men Building, Rm. 319  
1 Zuo Jia Zhuang  
Chao Yang District  
Beijing 100028  
People's Republic of China  
86-10-6468-7850  
86-10-6468-7788

### KOREA

No. 2110, 21 Fl. KEC Bldg.  
#275-7 Yangjea-dong  
Seocho-ku  
Seoul, 137-895, Korea  
82-2-3497-0401

### SHANGHAI

Asia Pacific Office  
23rd Floor, Aurora Plaza  
No. 99 Fucheng Road, Pudong  
Shanghai, 200120, China  
86-21-28996888

## SOUTH EAST ASIA AND OCEANIA

### AUSTRALIA

MTU Detroit Diesel Australia Pty Ltd.  
569 Grand Junction Road  
Gepps Cross, South Australia  
Australia 5094  
61-8-8300-8100

### SINGAPORE

Allison Transmission  
15 Benoi Sector  
Jurong Town, Singapore 629849  
65-6267-1600

## SOUTH AMERICA

### BRAZIL

Allison Transmission  
Rua Agostinho Togneri  
57 - Jardim Jurubatuba - Santo Amaro  
Sao Paulo (SP), Brazil CEP 04690-090  
55-11-5633-2599

### ARGENTINA, CHILE, PARAGUAY, URUGUAY, VENEZUELA

Av. Leandro Alem, 855  
Piso 2  
Buenos Aires, Capital Federal CP C1001AAP  
Argentina  
54-11-4510-2758

